

Regulations under the *Scaffolding Inspection Ordinance* 1932-1961.

I, ROGER BEDE NOTT, the Administrator of the Northern Territory of Australia, having received the advice of the Administrator's Council, in pursuance of the powers conferred on me by the *Scaffolding Inspection Ordinance* 1932-1961, and the *Administrator's Council Ordinance* 1959, hereby make the following Regulations.

Dated this fifth day of February, 1962.

ROGER NOTT,
Administrator.

SCAFFOLDING REGULATIONS.

PART I.—PRELIMINARY.

1. These Regulations may be cited as the Scaffolding Regulations. Citation.
2. These Regulations are divided into parts as follows:— Parts.
 - Part I.—Preliminary (Regulations 1-3).
 - Part II.—Administration (Regulations 4-8).
 - Part III.—Requirements for Scaffolding and Gear (Regulations 9-27).
 - Part IV.—Requirements for Rigging (Regulations 28-30).
 - Part V.—Offences (Regulation 31).
3. In these Regulations, unless the contrary intention appears— Definitions.
 - “approval” means approval of an inspector;
 - “approved” means approved by an inspector;
 - “estimated costs”, in relation to work in connexion with which it is proposed to erect scaffolding, or do rigging means the total cost of the completed work as estimated by the person for whom the work is being carried out at the time when notice is given under section six of the Ordinance;
 - “height” in relation to scaffolding, means the perpendicular distance measured from the base from which the scaffolding rises to the top surface of the topmost platform;
 - “licensed” means licensed under this Ordinance;
 - “the Ordinance” means the *Scaffolding Inspection Ordinance* 1932-1961;
 - “timber” means Australian hardwood or oregon pine.

PART II.—ADMINISTRATION.

4.—(1.) An applicant for a scaffolder's licence under the Ordinance shall—

- (a) produce satisfactory evidence of his respectability of character;
- (b) produce a medical certificate that he is not suffering from any affliction of the heart or other ailment likely to interfere with the efficient exercise by him of the trade of a scaffolder;
- (c) pass, to the satisfaction of the Administrator, or a person authorized by him in writing, an oral, or if the Administrator directs, a written examination to test whether he possesses—
 - (i) a sound knowledge of the English language;
 - (ii) a sound knowledge of such parts of the Ordinance and these Regulations as relate to scaffolders and scaffolding;
 - (iii) a thorough knowledge of all material used for or in connexion with scaffolding and gear;
 - (iv) ability to construct and to erect various kinds of scaffolding used in connexion with building or structural operations;
 - (v) a sound knowledge of elementary mathematics; and
 - (vi) ability to make a good free hand sketch or working drawings of any kind of scaffolding.

(2.) An applicant for a rigger's licence shall—

- (a) produce satisfactory evidence of his respectability of character;
- (b) produce a medical certificate that he is not suffering from any affliction of the heart or other ailment likely to interfere with the efficient exercise by him of the trade of a rigger;
- (c) pass to the satisfaction of the Administrator, or a person authorized by him in writing, an oral, or if the Administrator directs, a written examination to test whether he possesses—
 - (i) a sound knowledge of the English language;
 - (ii) a sound knowledge of such parts of the Ordinance and these Regulations as relate to riggers and rigging;
 - (iii) a sound knowledge of the measures and precautions to be taken to prevent accidents in connexion with rigging;
 - (iv) a sound knowledge of the safe working loads of ropes, chains and slings, the splicing and knotting of ropes and the making of slings;
 - (v) a sound knowledge of the safe working loads for, and the use of, gear and equipment; and
 - (vi) a sound knowledge of the slinging and lifting of heavy loads; and
- (d) demonstrate to the satisfaction of the Administrator or a person authorized by him in writing, his ability to climb and work at heights.

5. The fee to accompany an application under section five A of the Ordinance is Two pounds.

6.—(1.) A person shall not use any scaffolding or gear unless it has been inspected by an inspector.

Applicants to pass examination and comply with other requirements.

Fee on application.

Periodical inspection of scaffolding.

(2.) Where on inspection an inspector is of the opinion that scaffolding or gear is unsafe he shall mark it clearly as unsafe.

(3.) A person shall not use scaffolding or gear marked as unsafe by an inspector.

(4.) Where an inspector marks scaffolding or gear as unsafe the inspector shall give notice of that fact in writing to the owner of the scaffolding or gear.

7.—(1.) A notice under section six of the Ordinance shall set out—

- (a) the name and address of the owner of the scaffolding or gear or of the structure, crane or hoist to be erected, set up, demolished or dismantled;
- (b) the name and address of the person who is to supervise the erection of the scaffolding or the rigging;
- (c) the date on which erection of the scaffolding or rigging will commence; and
- (d) the place where the scaffolding will be erected or the rigging is to be done.

Notice of
intention
to erect
scaffolding.

8.—(1.) The fee to accompany a notice under section six of the Ordinance is—

- (a) where the work in connexion with which the scaffolding is being erected or the rigging is being done is not a dwelling house and the estimated cost of the work does not exceed One thousand pounds, One pound;
- (b) where the work in connexion with which the scaffolding is being erected or the rigging is being done is not a dwelling house and the estimated cost of the work exceeds One thousand pounds, One pound together with an additional Ten shillings for each succeeding One thousand pounds of the estimated cost;
- (c) where the work in connexion with which the scaffolding is being erected, or the rigging is being done is the construction of—
 - (i) a wooden dwelling house, Two pounds; and
 - (ii) a brick, masonry or concrete dwelling house, Three pounds.

Fees to
accompany
notice.

(2.) For the purposes of this regulation, “dwelling house” means—

- (a) in the case of a building all or part of which is intended to be let or occupied in flats, each flat of the building; and
- (b) in any other case, a building intended to be let or used exclusively as a place of residence.

PART III.—REQUIREMENTS FOR SCAFFOLDING AND GEAR.

9. On all scaffolding works there shall be at least one licensed supervision. scaffolder employed or engaged in work as a scaffolder on those works.

10.—(1.) A person shall not use scaffolding or gear unless that scaffolding or gear, as the case may be, complies with the provisions of these Regulations.

Scaffolding
and gear to
comply with
requirements.

(2.) Where scaffolding or gear, as the case may be, does not comply with such provisions of these Regulations as are set down elsewhere than in this sub-regulation, the scaffolding or gear may be used if, in the opinion of an inspector its safety is not decreased because it does not comply with those provisions.

(3.) A person in charge of scaffolding or gear shall provide proper safeguards to prevent material and debris falling from the scaffolding or gear.

(4.) A person in charge of scaffolding or gear shall, during the progress of any work, ensure that—

- (a) the scaffolding or gear is hoisted or lowered and adequately suspended or supported and not thrown to the ground;
- (b) a safe means of access is provided to all working platforms and other working places by means of ladders, ramps or stairways;
- (c) all places to which access is required for any person and every means of approach to a place to which access is required for any person are efficiently lighted;
- (d) proper safeguards are provided to prevent and guard workmen and others from coming into contact with electric wires or dangerous equipment;
- (e) proper safeguards are provided for the protection of workmen who, in the course of their duties, work or carry materials over floor joists;
- (f) where men are working below scaffolding, safeguards to protect them are provided;
- (g) a well hole, a stairway or an opening in a floor is guarded by an approved board and railing; and
- (h) barrow runs, barrow skids and landings for barrows comply with these regulations.

Erection and use to be in accordance with Regulations.

11. A person shall not—

- (a) erect a scaffolding with material other than approved material;
- (b) erect a scaffolding otherwise than in accordance with these Regulations; and
- (c) use a scaffolding for purposes other than the purposes specified in these Regulations.

General requirements.

12. Unless it is elsewhere in these Regulations otherwise provided, a person in charge of the erection of scaffolding shall ensure that—

- (a) the cross sectional dimensions of scaffold planks are—
 - (i) where the plank is of Australian hardwood, not less than 9 inches by 1½ inches; or
 - (ii) where the plank is of oregon pine, not less than 9 inches by 1½ inches;
- (b) a working platform is—
 - (i) not less than 18 inches in width;
 - (ii) over the full length of the scaffolding frame;

- (iii) of scaffold planks of uniform thickness so as to provide an even surface; and
 - (iv) lapped 9 inches over the supports;
- (c) guard rails are—
- (i) of timber the strength and rigidity of which is not less than the strength and rigidity of oregon pine of cross sectional dimensions of 4 inches by 2 inches or of metal piping having an external diameter of not less than $1\frac{1}{2}$ inches;
 - (ii) 36 inches in height from the working platform; and
 - (iii) securely fixed to standards in all cases where the working platform is set at a greater height than 8 feet;
- (d) toe boards of timber not less than 1 inch in thickness are secured to the standards at the edges and the ends of each working platform so that they shall project not less than 9 inches above the surface of the working platform;
- (e) fixings are—
- (i) steel bolts $\frac{3}{8}$ of an inch in thickness with washers and nuts;
 - (ii) lashings of round fibre rope; or
 - (iii) other approved fixings,
- and otherwise comply with the requirements prescribed;
- (f) where the scaffolding erected is a tubular scaffolding the pipes used in erecting that scaffolding are—
- (i) straight;
 - (ii) free from indentations, corrosion and other defects;
 - (iii) with squared ends to ensure even bearing over the whole area of the section of joints and other connections; and
 - (iv) of dimensions and materials prescribed.
- (g) fittings are not used in connexion with tubular scaffolding unless—
- (i) the fittings are approved;
 - (ii) where the efficacy of a fitting is dependent upon frictional grip, that fitting is so used as not to transmit primary tensile forces; and
 - (iii) the fittings and the whole area of their bearing surfaces, accurately embrace the component part or parts on which they are used;
- (h) where scaffolding is to be erected within 15 feet of any overhead conductor of electricity or within 15 feet of any transmission apparatus, the overhead conductor or the transmission apparatus is protected to the satisfaction of the Administrator or a person authorized by him in writing;
- (j) fibre rope is not used in connexion with scaffolding which is erected in or near a place where acids are generated or released.

Ladders.

13. Ladders used in connexion with scaffolding shall be—

- (a) of maximum length of 30 feet;
- (b) of maximum inside width of 22 inches and minimum inside width of 13 inches; and
- (c) constructed in a manner and of materials approved by an inspector.

Barrow runs, &c.

14.—(1.) Barrow runs shall be—

- (a) of timber planks 12 inches by 2 inches or 9 inches by 1½ inches;
- (b) 3 feet wide;
- (c) supported at intervals not greater than 8 feet in the case of planks 12 inches by 2 inches or 6 feet in the case of planks 9 inches by 1½ inches; and
- (d) connected with not less than 3 timber cleats of cross sectional dimensions of 2 inches by 1 inch spaced evenly between supports and secured to the underside of the planks by nails or screws.

(2.) Skids for barrows shall be 12 scaffold planks wide.

(3.) Landings for barrows shall be 12 scaffold planks wide and not less than 14 feet long.

Scaffolding for bricklayers, &c.

15.—(1.) Where scaffolding not exceeding thirty feet in height is erected for the use of brick layers, plasterers, masons and other like tradesmen, the standards, ledgers, putlogs and bracings shall comply with sub-regulations (2.), (3.), (4.) and (5.) of this regulation and the scaffolding shall, subject to regulation 12 of these Regulations, be so erected that—

- (a) all standards are tied to the building or structure or, otherwise, are braced at points not more than 12 feet apart along the length of each standard;
- (b) all standards are spaced not more than 10 feet apart or, in the case of pipe standards in tubular scaffolding, 7½ feet apart measured, in either case, from the centre line of one standard to the centre line of the adjacent standard;
- (c) where two or more rows of standards are used, the rows are spaced not more than 5 feet apart or, in the case of pipe standards in tubular scaffolding not more than 4½ feet apart;
- (d) ledgers are spaced not more than 6 feet apart;
- (e) putlogs are spaced six feet apart except in the case of tubular scaffolding where the putlogs shall be placed at each side of each standard other than the standards at each end of the scaffolding frame where only one need be placed; and
- (f) where only one row of standards are used, the inner end of each putlog bears not less than 4½ inches in the wall of the building.

(2.) All standards shall be—

- (a) of sawn timber of cross sectional dimensions of 4 inches by 3 inches;
- (b) of timber poles not less than 3 inches in diameter at the small end; or

(c) in the case of tubular scaffolding only, of round metal pipes, of steam quality, mild steel or other approved alloy of an outside diameter of not less than $1\frac{3}{8}$ inches, a nominal bore of $1\frac{1}{2}$ inches and a wall thickness of not less than 0.192 inches if of mild steel or 0.176 inches if an approved alloy.

(3.) All ledgers shall be—

- (a) of sawn timber of cross sectional dimensions of not less than 6 inches by $1\frac{1}{2}$ inches;
- (b) of timber poles not less than $2\frac{1}{2}$ inches in diameter at the small end; or
- (c) in the case of tubular scaffolding, pipes of the description and dimensions of the pipes used for standards in that particular scaffolding.

(4.) Putlogs shall be—

- (a) of sawn timber of cross sectional dimensions of not less than 3 inches by 3 inches if of Australian hardwood or not less than 4 inches by 3 inches if of oregon pine; or
- (b) in the case of tubular scaffolding of pipes of the description and dimensions of the pipes used for standards in that particular scaffolding.

(5.) Bracings shall be—

- (a) of sawn timber not less than 9 square inches in cross sectional area;
- (b) of timber poles not less than $2\frac{1}{2}$ inches in diameter at the small end; or
- (c) in the case of tubular scaffolding, pipes of the description and dimensions of the pipes used for standards in that particular scaffolding.

16.—(1.) Where scaffolding exceeding thirty feet but not exceeding one hundred and fifty feet in height is erected for the use of tradesmen specified in the last preceding regulation the standards, ledgers, putlogs and bracings shall comply with sub-regulations (2.), (3.), (4.) and (5.) of this regulation and the scaffolding shall, subject to regulation 12 of these Regulations, be so erected that—

Scaffolding for bricklayers, &c., exceeding thirty feet in height.

- (a) all standards are tied to the building or structure or otherwise braced at points not more than 12 feet apart along the length of each standard;
- (b) all standards are spaced not more than 9 feet, or in the case of pipe standards in tubular scaffolding not more than $7\frac{1}{2}$ feet apart measured in either case from the centre line of one standard to the centre line of the adjacent standard;
- (c) where two or more rows of standards are used, the rows are spaced not more than 5 feet apart or, in the case of pipe standards in tubular scaffolding, not more than $4\frac{1}{2}$ feet apart;
- (d) ledgers are spaced at not more than 6 feet apart;
- (e) putlogs are spaced not more than 6 feet apart except in the case of a tubular scaffolding where the putlogs shall be placed at each side of each standard other than the standards at each end of the scaffolding where one only need be placed; and

- (f) where only one row of standards are used, the inner end of each putlog bears not less than $4\frac{1}{2}$ inches in the wall of the building.
- (2.) All standards shall be—
- (a) of sawn timber of cross sectional dimensions of 4 inches by 4 inches;
 - (b) of timber poles of the dimensions specified in paragraph (b) of sub-regulation (2.) of the last preceding regulation; or
 - (c) in the case of tubular scaffolding, pipes of the description and dimensions specified in paragraph (c) of sub-regulation (2.) of the last preceding regulation.
- (3.) All ledgers shall be—
- (a) of sawn timber of cross sectional dimensions of 6 inches by $2\frac{1}{2}$ inches;
 - (b) of timber poles of the dimensions specified in paragraph (b) of sub-regulation (3.) of the last preceding regulation; or
 - (c) in the case of a tubular scaffolding, pipes of the description and dimensions of the pipes used for standards in that particular scaffolding.
- (4.) Putlogs shall be—
- (a) of sawn Australian hardwood of cross sectional dimensions of not less than 3 inches by 3 inches; or
 - (b) in the case of tubular scaffolding, of pipes of the description and dimensions of the pipes used for standards in that particular scaffolding.
- (5.) Bracings shall be—
- (a) of sawn timber not less than 9 square inches in sectional area;
 - (b) of timber poles not less than $2\frac{1}{2}$ inches in diameter at the small end; or
 - (c) in the case of tubular scaffolding, pipes of the description and dimensions of the pipes used for standards in that particular scaffolding.

Number of
platforms
to be set on
scaffolding for
bricklayers, &c.

17.—(1.) Two platforms of full length or a greater number of shorter length may be set up on a scaffolding frame erected under the last two preceding regulations but so that where more than two platforms are set up, the total area supported by any standard shall not exceed that supported by any standard where two platforms of full length are set up.

(2.) The load due to the weight of men and materials uniformly distributed over the area of a platform shall not exceed thirty-five pounds per square foot of platform area and the weight of a concentrated load imposed upon any bay of a scaffolding erected under the last two preceding regulations shall not exceed four hundred pounds.

Scaffolding
for the use of
carpenters,
painters, &c.

18.—(1.) Where scaffolding not exceeding twenty-four feet in height is erected for the use of carpenters, decorators, plumbers, electrical welders or other like tradesmen, the standards, ledgers, putlogs and bracings shall

comply with sub-regulations (2.), (3.), (4.) and (5.) of this regulation and the scaffolding shall, subject to regulation 12 of these Regulations, be so erected that—

- (a) all standards are spaced, in the case of timber poles or sawn timber, not more than 12 feet apart or, in the case of round steel pipe specified in paragraph (c) of the next succeeding sub-regulation, not more than 6 feet apart, in either case measured from the centre line of one standard to the centre line of the adjacent standard;
 - (b) where two or more rows of standards are used, the rows are spaced not more than five feet apart or, in the case of standards of round steel pipe specified in paragraph (c) of the next succeeding sub-regulation, not more than 3 feet 9 inches apart;
 - (c) ledgers are spaced at not more than 6 feet apart the lowest ledgers being fixed at a height not exceeding 18 inches above the feet of the standards;
 - (d) putlogs are connected directly to the standards and the fittings set together as closely as practicable; and
 - (e) where only one row of standards is used the inner end of each putlog bears not less than 4½ inches in the wall of the building.
- (2.) All standards shall be—
- (a) of sawn timber of not less than 4 inches by 2 inches in cross sectional dimensions;
 - (b) of timber poles not less than 2½ inches at the small end; or
 - (c) in the case of tubular scaffolding, of mild steel round pipes of steam quality not less in outside diameter than 1½ inches and having walls not less than 0.16 inches in thickness.
- (3.) All ledgers shall be—
- (a) of sawn timber of cross sectional dimensions of not less than 6 inches by 1½ inches;
 - (b) of timber poles not less than 2½ inches at the small end; or
 - (c) in the case of standards of round steel pipe specified in paragraph (c) of the last preceding sub-regulation, of pipe of the same description and dimensions.
- (4.) Putlogs shall be—
- (a) of sawn timber of cross sectional dimensions of 3 inches by 3 inches if of Australian hardwood or, 4 inches by 3 inches if of oregon pine; or
 - (b) in the case of tubular scaffolding with standards of pipe specified in paragraph (c) of sub-regulation (2.) of this regulation, of pipe of the same description and dimensions.
- (5.) Bracings shall be—
- (a) of sawn timber not less than 9 square inches in sectional area;
 - (b) of timber poles not less than 2½ inches in diameter at the small end; or
 - (c) in the case of tubular scaffolding with standards of pipe specified in paragraph (c) of sub-regulation (2.) of this regulation, of pipe of the same description and dimensions.

Scaffolding
for carpenters,
painters, &c.,
exceeding
twenty-four
feet in height.

19. Where scaffolding erected for the use of tradesmen specified in the last preceding regulation exceeds the height of twenty-four feet but does not exceed the height of one hundred feet—

- (a) the standards may be spaced at not more than 12 feet apart;
- (b) where two or more rows of standards are used, the rows may be spaced at not more than 6 feet apart; and
- (c) in all other respects the scaffolding shall be erected in manner and with materials of the description and dimensions set out in regulation 16 of these Regulations.

20.—(1.) Two platforms of full length or a greater number of shorter length may be set up on a scaffolding frame erected under the last two preceding regulations but so that where more than two platforms are set up, the total area supported by any standard shall not exceed that supported by any standard where two platforms of full length are set up.

(2.) The load due to the weight of men and materials on a platform set up on scaffolding erected under the last two preceding regulations shall not exceed ten pounds per square foot of platform area.

Scaffolding
for the use of
interior work.

21.—(1.) Where a scaffolding is erected for the use of interior painters or decorators only—

- (a) the platform planks may be spaced not more than 7 inches apart;
- (b) the span of a mild steel putlog may be not more than 8 feet;
- (c) the span of a high tensile aluminium pipe may be not more than 6 feet;
- (d) the standards shall be spaced not more than ten feet apart; and
- (e) in all other respects the scaffolding shall, subject to this regulation, be erected—
 - (i) where the height of the scaffolding exceeds 24 feet but does not exceed 100 feet, in the manner and with materials of the description set out in regulation 19 of these Regulations; or
 - (ii) where the height of the scaffolding does not exceed 24 feet, in the manner and with materials of the description and dimensions set out in regulation 18 of these Regulations.

(2.) Not more than one working platform may be set up on a scaffolding frame erected under the last preceding sub-regulation.

(3.) The total load on a working platform in any bay of scaffolding erected under sub-regulation (1.) of this regulation shall not exceed the weight of two men and in addition the weight, not exceeding fifty pounds, of material.

(4.) Notwithstanding anything contained in these Regulations, a scaffolding for painters or decorators only may be erected—

- (a) where the height of the scaffolding does not exceed 10 feet, with approved steps or trestles, in either case not more than 8 feet apart, and one plank for a working platform; or
- (b) where the height of the scaffolding exceeds 10 feet but does not exceed 16 feet, with approved trestles not more than 8 feet apart and two planks for a working platform.

22.—(1.) A cantilever scaffolding shall be erected so that—

Cantilever
scaffolding.

- (a) the general arrangement of its component members is as shown in Plate I in the Schedule to these Regulations;
- (b) the working platform is not more than 4½ feet in width unless otherwise approved;
- (c) the scaffold planks forming the working platform are spiked, strapped, lashed or wired in position to overcome creep and prevent displacement;
- (d) the cross sectional dimensions of scaffold planks, forming the working platform are in the case of spans not exceeding 6 feet, 10 inches by 1½ inches or, in the case of spans exceeding 6 feet but not exceeding 10 feet, 10 inches by 2 inches;
- (e) guard rails are securely fixed at the open sides and ends of the platform;
- (f) toe boards are securely fixed at the open side of the platform;
- (g) the length of a cantilever inside a building or structure is not less than 8 feet measured horizontally from the centre line of the cantilever support to the centre of the bolt fixing the inboard end to its support;
- (h) the cross sectional dimensions of a cantilever are not—
 - (i) where the distance between the centre lines of adjacent cantilevers does not exceed 6 feet, less than 9 inches by 2½ inches in the case of oregon pine or 9 inches by 2 inches in the case of Australian hardwood; or
 - (ii) where that distance is more than 6 feet but does not exceed 10 feet, 10 inches by 2½ inches in the case of oregon pine or 10 inches by 2 inches in the case of Australian hardwood;
- (j) the inboard ends of the cantilevers are fixed to forms of cross sectional dimensions of not less than 4 inches by 3 inches; and
- (k) the forms and cantilevers are respectively braced by timber braces of sectional dimensions of 3 inches by 2 inches fixed by bolts with washers.

(2.) A scaffolding erected in accordance with the last preceding sub-regulation may, with approval, be used by carpenters, painters, brick layers, plumbers and other like tradesmen where it is not practicable to erect a scaffolding with standards.

23.—(1.) A bracket scaffolding shall be erected so that—

Bracket
scaffolding
for use of
carpenters,
painters, &c.

- (a) the general arrangement of its component members is in accordance with Plate II in the Schedule to these Regulations;
- (b) the brackets are not spaced at more than fourteen feet apart;
- (c) each bracket consists of—
 - (i) a vertical leg of not less than 4 feet in length with cross sectional dimensions of 4 inches by 3 inches in the case of oregon pine or 4 inches by 2 inches in the case of Australian hardwood; and
 - (ii) a horizontal leg not exceeding 2½ feet in length with cross sectional dimensions set out in the last preceding sub-paragraph the inboard of which shall sit

square on the upper end of the vertical leg both being connected to each other by a fourteen gauge mild steel plate gusset 14 inches long fixed with two mild steel bolts $\frac{3}{8}$ inches in diameter and braced with one pair of braces of sawn timber of cross sectional dimensions of 3 inches by 1 $\frac{1}{2}$ inches cut at each end to form a shoulder bearing against the horizontal and vertical legs of the bracket respectively;

- (d) hand rail brackets of mild steel plate $\frac{3}{16}$ of an inch thick are fixed to the outer end of the horizontal leg of each bracket by mild steel bolts $\frac{3}{8}$ of an inch in diameter and the hand rail upright is bolted to the hand rail bracket;
 - (e) each bracket is held against the wall by a timber strut of cross sectional dimensions of 4 inches by 3 inches where the length of the strut does not exceed 20 feet or of such dimensions, where the strut is greater than 20 feet in length, as are approved;
 - (f) the struts are placed so that—
 - (i) their angle with the horizontal is not greater than 60° and not less than 50°; and
 - (ii) their lower ends are secured against movement;
 - (g) the struts are braced with timber braces of sectional dimensions of 3 inches by 1 $\frac{1}{2}$ inches fixed in position with clamps or bolts as illustrated in Plate II in the Schedule to these Regulations;
 - (h) the working platform which shall be not more than 2 $\frac{1}{2}$ feet and not less than 1 $\frac{1}{2}$ feet in width is of scaffold planks having a thickness of—
 - (i) where the scaffold planks are of oregon pine and the distance between the brackets does not exceed 12 feet, not less than 1 $\frac{1}{2}$ inches;
 - (ii) where the scaffold planks are of Australian hardwood and the distance between the brackets does not exceed 12 feet, not less than 1 $\frac{1}{2}$ inches;
 - (iii) where the scaffold planks are of oregon pine and the distance between the brackets exceeds 12 feet, not less than 1 $\frac{3}{4}$ inches; or
 - (iv) where the scaffold planks are of Australian hardwood and the distance between the brackets exceeds 12 feet, not less than 1 $\frac{3}{4}$ inches; and
 - (j) hand rails of cross sectional dimensions of 3 inches by 2 inches are fixed surrounding the outer edge and ends of the working platform by means of the hand rail brackets.
- (2.) Where bracket scaffolding consists of metal brackets—
- (a) the scaffolding shall be erected in accordance with the directions of an inspector; and
 - (b) a working platform supported by the scaffolding shall comply with such of the requirements of the last preceding sub-regulation as are applicable to working platforms.

(3.) A scaffolding erected in accordance with this regulation may with approval be used by carpenters, painters, plumbers or other like tradesmen but shall not be used by any one else.

24.—(1.) Suspended scaffolding shall be erected so that under maximum conditions of loading the unit stress in each and every portion of each component member and its connexion shall not exceed the ultimate unit strength of the material used, divided—

Suspended scaffolding for use in places and for purposes approved by an inspector.

- (a) in the case of steel overhead supports, steel fittings and bolts, by 4;
- (b) in the case of steel structure component members, by 4;
- (c) in the case of steel wire suspension ropes, their fittings and attachments, by 6;
- (d) in the case of parts of operating and winding mechanisms, by 6; and
- (e) in the case of timber used for supporting and transferring counterbalance load to needles, by 6.

(2.) Ropes to be used in a suspended scaffolding shall be steel wire ropes of approved flexibility.

(3.) Spliced eyes in ropes shall be round thimbles and shall have not less than three full tucks.

(4.) The terminal ends of ropes shall be securely fixed to anchorages of ultimate strength of not less than that of the rope.

(5.) A scaffolding machine, winch or other mechanism shall not be used for lifting or lowering a suspended scaffolding unless drawings or samples of that machine, winch or other mechanism together with a detailed description in writing of the manner in which it is to be erected, used and maintained are first submitted to and approved by the Chief Inspector of Machinery.

(6.) All scaffolding machines shall be erected, used and maintained in a manner approved by the Chief Inspector of Machinery.

(7.) Each of the cantilevers constituting the overhead supports for a suspended scaffolding—

- (a) shall consist of rolled steel joist sections;
 - (b) shall be not less than 18 feet in length;
 - (c) shall not project more than $6\frac{1}{2}$ feet from the outside point of support on the building or structure in connexion with which it is used;
 - (d) shall be positioned so that the distance between its longitudinal centre line and the longitudinal centre line of the other cantilever is not more than 10 feet; and
 - (e) shall be adequately supported with supports arranged so that the projecting portion of the cantilever is as short as possible.
- (8.) The inner end of each suspended scaffolding cantilever shall be—
- (a) fixed to the building or structure with bolts or other approved fittings; and
 - (b) counterbalanced with a weight not less than three times that necessary to balance the load on its projecting part when the scaffolding is fully loaded or shored from a higher floor

or steel frame of a building or structure, so that each shore is fixed correctly in position to prevent lateral movement and undue load being imposed on any part of the building or structure supporting the cantilever.

(9.) Mild steel iron straps formed of sections not less than 2 inches by $\frac{3}{8}$ of an inch shall be fixed to the top and sides of the outer end of every suspended scaffolding cantilever so that their bottom ends make an angle of not less than 75° with the bottom surface of the cantilever and their inside faces are not less than 1 inch apart.

(10.) No person shall work a machine, winch, or other mechanism used for raising or lowering a suspended scaffolding unless he is authorized so to do by his employer and no employer shall so authorize a person under the age of eighteen years.

(11.) A suspended scaffolding shall not be used where, in the opinion of an inspector—

- (a) the position of that scaffolding and the conditions under which it is intended to be used would constitute a danger to human life or limb;
- (b) the building or structure to which the scaffolding is attached or is proposed to be attached is not suitable for the safe support of a suspended scaffolding; or
- (c) a suspended scaffolding is not suitable for the work proposed to be carried out.

25.—(1.) Where a light swinging stage is erected, it shall be erected so that—

- (a) the working platform is not more than 18 feet in length;
- (b) the scaffolding planks forming the working platform are of oregon pine not less than $1\frac{1}{2}$ inches thick, cleated at the centre and immediately adjacent to each hanger;
- (c) the span of the scaffold planks from the centre line of one hanger to the centre line of the other hanger is not more than 12 feet;
- (d) the overhang of the scaffold planks at each end does not exceed one quarter of the distance between the centre lines of the hangers;
- (e) a guard rail, of oregon pine of cross sectional dimensions of not less than 3 inches by 2 inches or of galvanized steel water pipe of equivalent strength, is securely fixed to the hangers at not more than $2\frac{1}{2}$ inches above the surface of the platform;
- (f) a toeboard of cross sectional dimensions of not less than 6 inches by 1 inch is securely fixed on the sides and ends of the working platform;
- (g) each hanger supporting the working platform—
 - (i) is a steel bar of cross sectional dimensions of 2 inches by $\frac{1}{2}$ an inch or a steel rod 1 inch in diameter;
 - (ii) passes under the platform; and
 - (iii) is securely fixed to the platform;

Light swinging stage for use in places and for purposes approved by an inspector.

- (h) the fall rope of a tackle used for raising and lowering the light swinging stage is of Manila or sisal fibre not less than $2\frac{1}{2}$ inches in circumference and reeved through a double and single block forming four parts of rope;
- (j) the carcase of every block for fibre rope used in the tackle for raising and lowering the light swinging stage is of steel, the sheaves of each block being not less than 4 inches in diameter, measured at the bottom of the rope groove;
- (k) rope blocks are fixed to needles with steel wire rope lashing or an approved steel fitting and their mouths are moused to prevent displacement;
- (l) needles are of Australian hardwood or oregon pine and—
 - (i) where the point of suspension of the fall rope top block is not more than 2 feet from the point of bearing of the needle on the building or structure are of cross-sectional dimensions of not less than 6 inches by 4 inches or, where that point of suspension is more than 2 feet, are of such greater cross sectional dimensions as will provide a transverse strength bearing the same proportion to 6 inches by 4 inches as the distance of the point of suspension bears to 2 feet;
 - (ii) are placed on edge;
 - (iii) are securely fixed to the building or structure with bolts, approved fittings or lashings or counter-balanced with approved weights of not less than three times the net weight required to balance the weight of the load of the projecting part of a needle when the stage is fully loaded; and
 - (iv) at all times other than the times when the light swinging stage is raised or lowered the hauling part of the fibre rope is capable of being and is fastened to the lower block with a self-locking switch.

(2.) Where a machine winch or other mechanism is used or intended to be used for raising and lowering a light swinging stage the provisions set out in sub-regulations (5.), (6.) and (10.) of the last preceding regulation apply.

26. A boatswain chair shall be of timber of not less than 1 inch thick and shall be so erected that—

Boatswain
chairs.

- (a) the seating space is not less than 18 inches by 10 inches;
- (b) cleats made of timber of cross sectional dimensions of not less than 3 inches by 1 inch are securely fixed to the ends of the timber, on the underside, forming the seat;
- (c) the slings supporting the boatswain chair—
 - (i) are of fibre rope of not less than $1\frac{1}{2}$ inches in circumference;
 - (ii) are crossed and fixed to the underside of the seat;
 - (iii) are arranged so that each leg of the sling passes through a corresponding hole in each corner of the seat; and

- (iv) form a loop over the seat to take a rope pulley block hook;
- (d) the rope blocks included in the tackle for suspending and raising and lowering the boatswain's chair are, in the case of the upper block, a two sheave block and, in the case of the lower block, a single sheave block, with the rope sheaves in either case not less than 4 inches in diameter and grooved to accommodate the tackle rope;
- (e) the rope of the tackle suspending the boatswain chair is—
 - (i) of Manila or sisal fibre;
 - (ii) not less than 2 inches in circumference; and
 - (iii) reeved to form a four part rope tackle; and
- (f) all overhead supports are securely fixed and are of sufficient strength to sustain not less than four times the weight to be suspended.

27. (1.) Where a large flying stage for use on ships in dock or on slips is erected it shall be erected so that—

Large flying stages.

- (a) the working platform is of scaffold planks of cross sectional dimensions of not less than 12 inches by 3 inches supported by stage ropes at distances not greater than 18 feet;
- (b) the stage ropes are of flexible steel wire rope $1\frac{1}{2}$ inches in circumference and—
 - (i) have an eye spliced in one end to go around the scaffold planks, the eye so spliced being not less than $4\frac{1}{2}$ feet in length;
 - (ii) have a shorter eye spliced at the other end to take a tail rope; and
 - (iii) are attached to the scaffold planks in the middle of the laps with one full turn of the large eye;
- (c) as many guy ropes of flexible steel wire rope of not less than $1\frac{1}{2}$ inches in circumference with fibre tail ropes of not less than 2 inches in circumference attached by means of spliced eyes as, in the opinion of the inspector are necessary, are used to secure the steadiness of the stage; and
- (d) the stage is provided with life lines of not less than $2\frac{1}{2}$ inches fibre rope securely fixed to the stage ropes by means of fibre rope lanyards not less than $1\frac{1}{2}$ inches in circumference at a height of not less than 30 inches above the surface of the scaffold planks.

PART IV.—REQUIREMENTS FOR RIGGING.

28.—(1.) All rigging shall be carried out by or under the supervision of at least one licensed rigger.

(2.) No fittings, devices or other material shall be used in connexion with rigging unless they comply with the requirements of these Regulations or are otherwise approved.

General.

29.—(1.) Where a hoist tower is set up—

- (a) the overall outside dimensions of the tower of that hoist shall be not less than 5 feet by 5 feet;

Hoists.

- (b) the height of the topmost platform shall not exceed 170 feet measured from the base of a corner pipe of the hoist tower to the surface of the topmost platform supporting the tower head rope sheaves; and
- (c) the hoist tower shall—
- (i) be constructed of round metal pipes of mild steel or pipes of an approved high tensile aluminium or other approved alloy of an outside diameter of not less than $1\frac{3}{8}$ inches of nominal bore of $1\frac{1}{2}$ inches and having a wall thickness of not less than 0.192 inches in the case of mild steel or 0.176 inches in the case of an approved alloy or of such other material construction and dimensions as may be approved;
 - (ii) be braced horizontally so that the distance between the braces does not exceed 5 feet and each brace extends not less than 9 inches past each standard;
 - (iii) be braced diagonally in accordance with the directions of an inspector but so that there is at least one brace in each section between the horizontal braces connected to those braces by a 90° coupler or fitting;
 - (iv) subject to the next succeeding paragraph, be kept upright by steel wire guy ropes, the breaking load of which is not less than four times the maximum load to which they are subjected, at each corner of and spaced at not more than 30 feet along the height of the tower and anchored so that the guy ropes will not be more than 90° apart in plan;
 - (v) where the hoist tower is set up within or contiguous to a building, be securely fixed to the building at each floor level; and
 - (vi) be enclosed and kept enclosed at all times up to a height of not less than 6 feet above the level of every floor, scaffolding working platform or stairway adjacent to the hoist tower;
- (d) the beams supporting the tower head rope sheaves shall be—
- (i) of Australian hardwood timber each of such sectional dimensions as will, in proportion to its length, provide a margin of safety of not less than that provided by a piece of Australian hardwood 6 feet in length with cross sectional dimensions of 6 inches by 4 inches;
 - (ii) of channel iron not less than 6 inches by 4 inches in cross sectional dimensions, fixed securely in position at both ends; or
 - (iii) of approved tubular steel, trussed to provide support to the centre of the beam;
- (e) the guy ropes shall be securely fixed to the corner standards and their respective anchorage with at least two bulldog wire rope grips;
- (f) safe means of access shall be provided to the tower head rope sheaves for maintenance work; and

- (g) all fittings, and the whole of their bearing areas, shall accurately embrace the member or members of the hoist on which they are used.
- (2.) The maximum diameter at the bottom of the groove of any hoist rope sheave or pulley shall be—
- (a) where the speed at which the rope is capable of being moved does not exceed two units, twenty times the diameter of that rope; or
- (b) where the speed at which the rope is capable of being moved exceeds two units, twenty times the diameter of the rope and in addition twice the diameter of the rope for every unit in excess of two units.
- (3.) For the purposes of the last preceding sub-regulation—
- (a) a unit is 60 feet per minute; and
- (b) where the number of units is not exact, that number shall be deemed to be the next highest integral.

30. All single mast derricks, sheerlegs, cranes and similar structures shall be set up used and maintained in an approved manner.

Setting up of derricks, &c., to be in manner approved.

PART V.—OFFENCES.

31. When any matter or thing is by these Regulations directed or forbidden to be done, or when any authority is given by these Regulations to any person to direct a matter or thing to be done and such act so directed to be done is not done or such act so forbidden to be done is done, a person who fails to comply with such direction shall be guilty of an offence.

Penalty: Twenty pounds.

General penalty.

THE SCHEDULE.

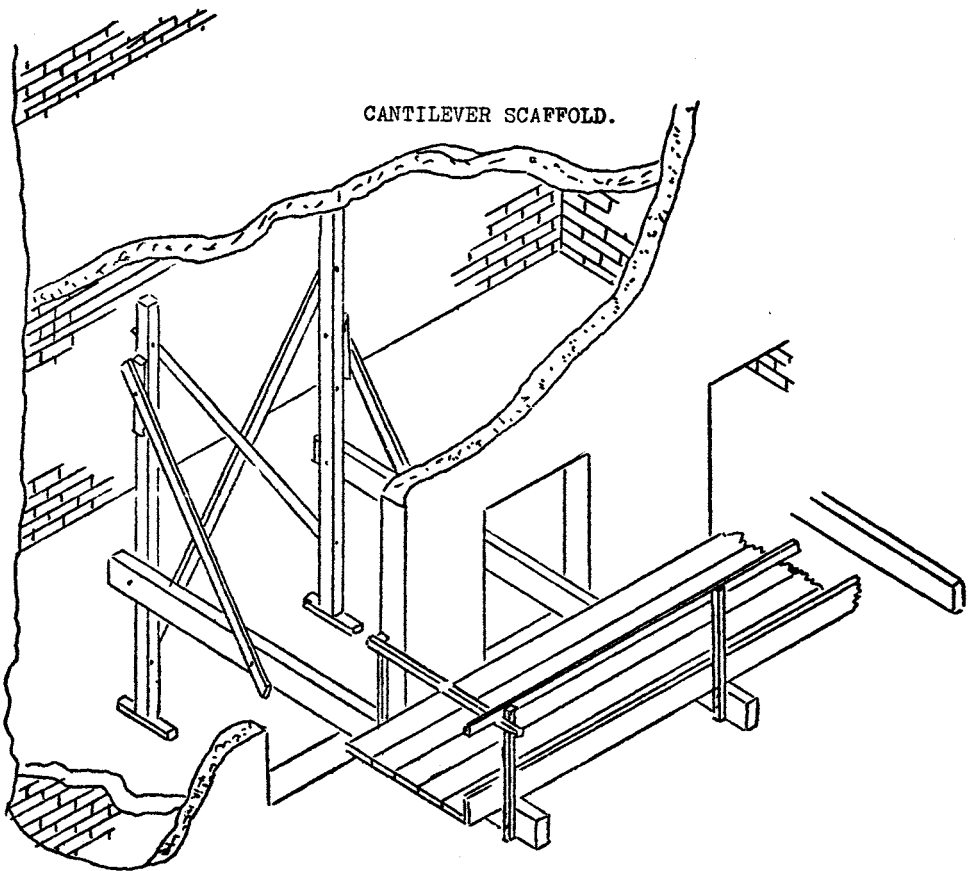
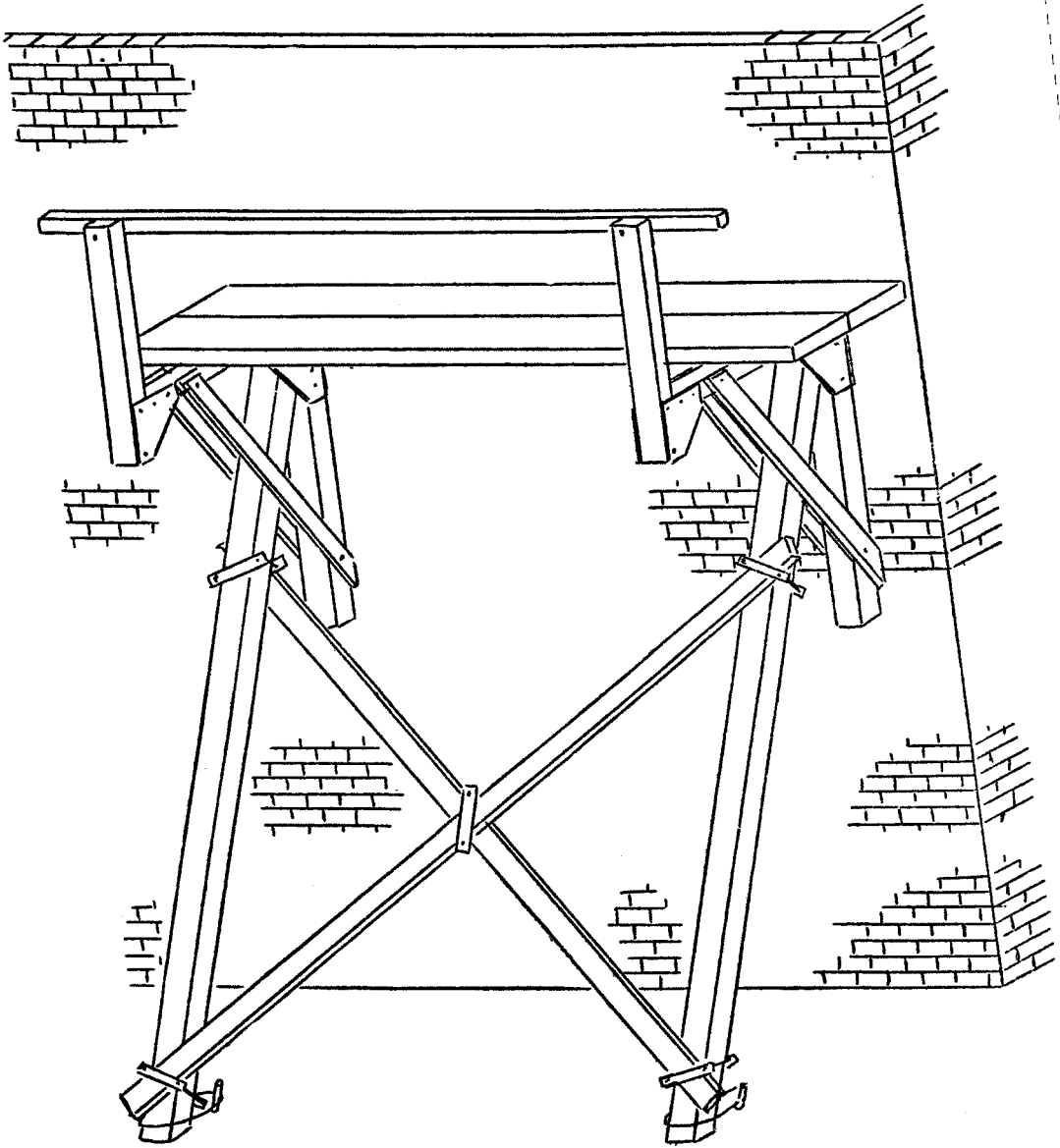

PLATE I.



BRACKET SCAFFOLD.

PLATE II.