



ANNO VICESIMO SECUNDO

GEORGII V REGIS.

A.D. 1931.

No. 2029.

An Act to consolidate certain Acts relating to Vermin Destruction and Vermin Fencing, and other matters.

[Assented to, November 26th, 1931.]

BE it Enacted by the Governor of the State of South Australia, with the advice and consent of the Parliament thereof, as follows :

PART I.

PRELIMINARY.

1. This Act may be cited as the "Vermin Act, 1931."

2. The provisions of this Act are arranged as follows—

PART I.—Preliminary.

PART II.—Vermin Destruction—

DIVISION I.—Government Inspectors :

DIVISION II.—Destruction on Crown Lands :

DIVISION III.—Powers and Duties of Councils and Vermin Boards :

DIVISION IV.—Destruction by Owners and Occupiers :

DIVISION v.—Destruction on Breakwind Reserves in Pinnaroo Railway District and on Drainage Lands.

PART III.—Vermin-Fenced Districts and Vermin Boards—

DIVISION I.—Interpretation :

DIVISION II.—Constitution of Vermin-Fenced Districts and Vermin Boards, and Suspension and Abolition of Boards :

PART I.

Short title.

Arrangement of Act.

PART I.

Vermin Act.—1931.

- DIVISION III.—Members of a Board :
- DIVISION IV.—Auditors :
- DIVISION V.—Elections :
- DIVISION VI.—Meetings of a Board and Committees thereof :
- DIVISION VII.—Contracts and Works :
- DIVISION VIII.—Revenue and Expenditure :
- DIVISION IX.—Making and Recovering Rates :
- DIVISION X.—Loans :
- DIVISION XI.—Officers of a District :
- DIVISION XII.—By-laws and Regulations :
- DIVISION XIII.—Differences between Boards :

PART IV.—Vermin Fencing and Dog-Proof Fencing by the Crown.

PART V.—Wire Netting and Vermin and Dog-Proof Fencing by Owners and Occupiers—

- DIVISION I.—General Provisions :
- DIVISION II.—Wire Netting by means of Loans to District Councils :
- DIVISION III.—Vermin and Dog-Proof Fencing by means of Loans to Vermin Boards :
- DIVISION IV.—Wire Netting outside District Council Districts and Vermin-Fenced Districts by means of Loans to Lessees under Pastoral and other Leases :
- DIVISION V.—Contribution to cost of Vermin, Dog-Proof, and Rabbit-Proof Fences by adjoining Occupiers :
- DIVISION VI.—Miscellaneous.

PART VI.—Miscellaneous Provisions.

PART VII.—Enforcement of the Act—

- DIVISION I.—Offences :
- DIVISION II.—Evidence :
- DIVISION III.—Legal Procedure.

Acts consolidated
and repealed.

3. (1) This Act is a consolidation of the Acts mentioned in the First Schedule, and the said Acts are hereby repealed to the extent therein mentioned.

(2) Wherever in any Act, or in any regulation, by-law, or rule, or any other document or instrument of any kind, any reference is made to any repealed Act, that reference shall be read and construed as a reference to this Act, or to the corresponding provision of this Act.

4. In

Vermin Act.—1931.

PART I.

4. In this Act, except where the subject matter or context or some other provision requires a different construction—

Interpretation.
1181, 1914, s. 4.
1249, 1916, s. 4.
1703, 1925, s. 66.
1869, 1928, s. 3.
1990, 1930, s. 4.

“ Authorised person ” means a person who, for the purpose of carrying into effect the provisions of Part II., is authorised and appointed in writing—

(a) by a District Council, as regards anything to be done within its District (except in cases where the provisions of subsection (1) or paragraph (a) of subsection (2) of section 11 are applicable):

(b) by a Vermin Board, as regards anything to be done within its Vermin-Fenced District:

(c) by an Associated Board, as regards anything to be done within its District:

(d) by the Commissioner, as regards anything to be done elsewhere than within the District of a District Council, Vermin Board, or Associated Board:

“ Associated Board ” means an Associated District Councils Vermin Board continued by this Act or constituted under section 12:

“ Board ” means the Vermin Board of a Vermin-Fenced District:

“ Chairman ” means Chairman of a Vermin Board:

“ Commissioner ” means the Commissioner of Crown Lands:

“ Crown lands ” means all lands in the State except—

i. lands reserved for or dedicated to any public purpose:

ii. lands lawfully granted, or contracted to be granted, in fee simple by or on behalf of the Crown:

iii. lands subject to any agreement, lease, or licence lawfully granted by or on behalf of the Crown:

and includes all lands which, having been granted or held under agreement or lease, have been or are surrendered, or, having been reserved or dedicated, have been or are lawfully resumed by proclamation; and all lands which, having been lawfully held by any person for any estate or interest, have been or are lawfully forfeited to or resumed by, or by any means whatsoever have reverted or revert to, the Crown:

“ Director of Lands ” means the Director of Lands for the time being, or the person for the time being discharging the duties of such Director of Lands:

“ District ” means Vermin-Fenced District:

“ District Council ” or “ Council ” means a District Council continued or established by or under the District Councils Act, 1929: “ Dog-proof

“ Dog-proof fence ” means—

(a) a substantial fence such as is shown and described in the Third Schedule ; or

(b) any other substantial dog-proof fence approved of in writing by the Commissioner :

“ Extraordinary vacancy ” means any vacancy in an office occurring otherwise than by effluxion of time :

“ Fixed rate ” means the annual rate of interest, fixed by the Commissioner or by the Bank under section 3 of the Vermin Act Further Amendment Act, 1912, under section 220 of the Vermin Act, 1914, or under section 216 of this Act, which was or is in force at the time when—

(a) the loan or advance in question, or with which the particular matter is connected, was or is made ; or

(b) the expenditure of the money in question, or with which the particular matter is connected, was or is authorised by the Governor or the Bank ; or

(c) the money in question, or with which the particular matter is connected, was or is expended by the Commissioner or the Bank,

as the case may be :

“ Member ” means member of a Board :

“ Owner or Occupier ” includes the authorised agent of any owner or occupier, and every person in receipt of or entitled to rents or profits of any land, and also includes a mortgagee in possession :

“ Rabbit-proof fence ” means—

(a) a substantial fence such as is shown and described in the Second Schedule ; or

(b) any other substantial rabbit-proof fence approved of in writing by the Commissioner :

“ Repealed Act ” means any Act repealed by this Act or repealed by an Act hereby repealed, or any other repealed Act which dealt with vermin destruction or vermin fencing :

“ Secretary ” means the Secretary to the Board :

“ The Bank ” means the State Bank of South Australia established by the State Bank Act, 1925 :

“ Town ” means any Government town or township, and any land laid out as a township, plans whereof are deposited in the Lands Titles Registration Office or in the General Registry Office for Deeds :

“ Vermin ” includes rabbits, wild dogs, and foxes, and any other animals which the Governor, by proclamation, declares to be vermin for the purpose of this Act :

“ Vermin-Fenced

Vermin Act.—1931.

PART I.

“ Vermin-Fenced District ” means Vermin-Fenced District continued by this Act, or constituted under Part III. or Part IV. of this Act :

“ Vermin fence ” means—

- (a) a substantial fence such as is shown and described in the Fourth Schedule ; or
- (b) any other substantial vermin fence approved of in writing by the Commissioner.

PART II.

PART II.

VERMIN DESTRUCTION.

DIVISION I.—GOVERNMENT INSPECTORS.

DIVISION I.

5. (1) The Commissioner may appoint such inspectors, sub-inspectors, and other officers as he thinks necessary for the efficient working of this Act, and may remove any person so appointed.

Power to appoint officers.
1181, 1914, s. 5.

(2) The Commissioner and every such inspector, sub-inspector, and other officer may, by writing under his hand, authorise such other person or persons as he deems necessary to carry or assist to carry this Act into effect.

DIVISION II.—DESTRUCTION ON CROWN LANDS.

DIVISION II.

6. The following provisions shall apply with respect to the destruction of vermin on Crown lands :—

Destruction of vermin on Crown lands within District Council Districts.
Ibid., s. 6.
1249, 1916, s. 4.
1990, 1930, s. 4.

- I. Any District Council may, by resolution, declare any Crown lands within its District, but which are not within a Vermin-Fenced District, to be vermin infested :
- II. Where all Crown lands within any such District Council District are not declared vermin infested, the resolution shall specify the Crown lands to which it refers :
- III. A copy of the resolution shall be forwarded to the Commissioner, who, if satisfied that the lands therein specified are vermin infested, shall forthwith publish in the *Gazette* a notice declaring the lands to be vermin infested, or, if satisfied that the lands are not vermin infested shall notify the Council to that effect :
- IV. When any Crown lands have been declared vermin infested under subdivision III. hereof, the Council may declare in respect of those lands such annual rate as is approved by the Commissioner, but not exceeding One Pound per square mile or part thereof, or such additional sum as is recommended by the Director of Lands and approved by the Commissioner :

v. The

PART II.
DIVISION II.*Vermin Act.—1931.*

- v. The total amount realised by the rate so declared shall be paid by the Commissioner to the Council, and shall be expended by the Council in and upon the destruction of the vermin on the said lands :
- vi. At the end of every year the Council shall forward to the Commissioner a statement of the actual expenditure for vermin destruction on Crown lands within the District. The said statement shall be certified as correct by the Chairman and Clerk of the Council :
- vii. If the amount expended by the Council is less than the amount paid to the Council as aforesaid by the Commissioner, the Council shall forthwith refund the difference to the Commissioner :
- viii. The Commissioner may at any time fence any such vermin infested Crown lands with a rabbit-proof fence, and the said lands shall upon the completion of the fence, and while the fence is maintained in an effective condition, cease to be liable to be rated under subdivision iv. hereof :
- ix. Where the Commissioner does not approve any rate declared under subdivision iv. hereof, he shall forthwith take all necessary and proper steps for the destruction of vermin upon the lands in respect of which the rate was declared.

Limit of liability for destruction of vermin by the Crown.

1181, 1914, s. 7.

DIVISION III.

7. Except as provided by section 6, the Crown shall be under no liability for the destruction of vermin upon Crown lands.

DIVISION III.—POWERS AND DUTIES OF COUNCILS AND VERMIN BOARDS.

Duty of Boards, Corporations, and Councils to destroy vermin on their land.

Ibid., s. 8.

1631, 1924, s. 6 (2).

8. (1) Subject to section 41, all Boards, Municipal Corporations, District Councils, and corporate bodies in whom any land (not being Crown lands) is vested, or who have the control of any land (not being Crown lands), shall, at their own expense, destroy all vermin on the land, not being main or district roads, vested in them respectively, or under their respective controls.

(2) Municipal Corporations and District Councils may expend any portion of their rates in complying with the provisions of this section.

Laying of poison for destruction of vermin.

1181, 1914, s. 9.

9. (1) Subject to subsection (2) hereof, any Vermin Board or Municipal or District Council may, for the purpose of carrying out its duties under this Act with regard to the destruction of vermin, lay poison or set traps on any land within the District or Municipality of the Board or Council, or on any Crown lands adjoining the District or Municipality.

(2) No poison shall be laid on any land under the provisions of this section unless notice of the poison being laid is conspicuously exhibited on the land, and no poison shall be so laid within one hundred yards of any public road or way.

10. All

*Vermin Act.—1931.*PART II.
DIVISION III.

10. All District Councils, Vermin Boards, and Associated Boards shall, within their respective Districts (but subject to section 11) strictly enforce the provisions of this Part as to the destruction of vermin.

Duty of Councils and Vermin Boards to enforce destruction of vermin.
Ibid., s. 10.

11. (1) Where the whole of the District of a District Council is within a Vermin-Fenced District, the provisions of this Part shall be carried out and enforced by the Vermin Board of that Vermin-Fenced District.

Lands within District Councils and Vermin Districts.
Ibid., s. 11.

(2) Where portion only of the District of a District Council is within a Vermin-Fenced District, the said provisions shall be carried out and enforced—

- (a) as regards the portion which is within the Vermin-Fenced District, by the Board of the Vermin-Fenced District :
- (b) as regards the portion which is not within the Vermin-Fenced District, by the District Council.

12. (1) For the purpose of more effectively carrying out the provisions of this Part for the destruction of vermin, any two or more District Councils whose Districts are contiguous may each nominate annually one of its members to be a member of a Board to be called an Associated District Councils Vermin Board.

Power of Councils to form Associated District Councils Vermin Boards.
Ibid., s. 12.

(2) Every member so nominated shall (unless he ceases to be a member of the Council by which he was nominated, or resigns his seat on the Board) continue in office for one year from the date of the proclamation referred to in subsection (3) hereof.

(3) The Governor may by proclamation declare any such Associated District Councils Vermin Board to be constituted, the names and residences of the members thereof, and the boundaries and limits of the District Council Districts under its control.

13. (1) When an Associated Board has been duly constituted, all the powers by this Act given to the Associated District Councils relating to the destruction of vermin within the boundaries specified in the proclamation constituting the Board shall be vested in the Board.

Powers of Associated Boards.
Ibid., s. 13.
1955, 1930, s. 6.

(2) The Board may appoint an inspector or inspectors, and may expend such moneys as are appropriated from its rates by each of the associated District Councils for the purposes of the Board, and generally may undertake such duties and exercise such powers and rights as are conferred by District Councils under this Act.

(3) The amount payable under this section by any of the associated District Councils to the Associated Board shall bear the same ratio to the aggregate amount payable by the associated District Councils as the amount of the assessment of that Council bears to the aggregate amount of the assessments of the associated District Councils: Provided that if the assessment of one or more of the associated District Councils is based upon annual values and the assessment of one or more of the associated District Councils is based

PART II.
DIVISION III.*Vermin Act.—1931.*

based upon land values the amounts payable as aforesaid shall be such as are fixed by the Commissioner upon application by the Associated Board.

Resignation of member of Associated Board. 1181, 1914, s. 14.

14. The seat upon an Associated Board of a member who ceases to be a member of the District Council by which he was nominated, or who resigns, shall thereupon be declared to be vacated, and a new nomination by the District Council shall be made.

Continuation of Associated Boards. *Ibid.*, s. 15.

15. Every Associated Board shall continue in existence for three years only from the date of the proclamation constituting the Board, unless the Governor by proclamation declares that the Board shall be continued for a further period from time to time, in which case a fresh nomination of members shall take place as hereinbefore provided.

Application of Part VIII. of District Councils Act, 1929, to Associated Boards.

16. The meetings of an Associated Board shall be regulated by the provisions of Part VIII. of the District Councils Act, 1929, so far as the same are applicable thereto.

Ibid., s. 16.

Failure to enforce vermin destruction. 1398, 1919, s. 3. 1567, 1923, s. 3.

17. (1) If the Commissioner has reason to believe that any District Council, Vermin Board, or Associated Board has failed or is failing to enforce strictly within its District the provisions of this Act as to the destruction of vermin, he shall immediately cause an inspection to be made of the District by a Government inspector.

(2) The Government inspector shall, after making an inspection, report to the Commissioner.

(3) The Commissioner may, if satisfied that the District Council, Vermin Board, or Associated Board has failed, or is failing, to enforce strictly the said provisions, give notice to the District Council, Associated Board, or Vermin Board requiring the District Council, Associated Board, or Vermin Board within one month of the giving of the notice to enforce strictly the said provisions.

(4) If any such District Council, Vermin Board, or Associated Board fails to comply with any such notice to the satisfaction of the Commissioner, the Commissioner may himself enforce within its District the provisions of this Act as to the destruction of vermin, and may recover from the District Council, Vermin Board, or Associated Board, by action in any Court of competent jurisdiction, the cost of so doing, or may deduct the said costs from any subsidy which the District Council, Vermin Board, or Associated Board is entitled to be paid under any Act.

(5) Any District Council, Vermin Board, or Associated Board failing to comply with a notice given under subsection (3) of this section shall, in addition to any liability incurred under subsection (4) of this section, be liable to a penalty of not less than Five Pounds nor more than Twenty Pounds for a first offence, and not less than Twenty Pounds nor more than Fifty Pounds for any subsequent offence.

(6) For

*Vermin Act.—1931.*PART II.
DIVISION III.

(6) For the purpose of enforcing the provisions of this Act as mentioned in subsection (4) of this section, the Commissioner may within any District exercise all the powers, functions, authorities, and discretions which the District Council, Vermin Board, or Associated Board itself might exercise.

(7) If the Commissioner in enforcing the provisions of this Act as mentioned in subsection (4) of this section, incurs expense in destroying or taking measures to destroy vermin on any land, not being land vested in or under the control of a Vermin Board, a Municipal Corporation, or a District Council, the Commissioner may, if he thinks fit, recover the amount of the said expense from the owner or occupier of the land instead of from the District Council, Vermin Board, or Associated Board.

(8) The Commissioner may also, in addition, withhold any subsidy payable to the District Council, Vermin Board, or Associated Board to which it may be entitled under any Act.

18. (1) A District Council, in addition to exercising the power conferred by subsection (2) of section 8, may, for the purpose of providing funds to carry out the purposes of this Act, declare an annual rate on all ratable property in the District. The said rate shall, where the assessment is based on annual value, not exceed Three Pence in the Pound and where the assessment is based on land value not exceed three-eighths of a Penny in the Pound.

Power of District Councils to declare rate for carrying out Act.

1181, 1914, s. 18.

(2) The said rate may be levied and recovered in the same manner as the general rate under the District Councils Act, 1929.

(3) Land enclosed with a rabbit-proof fence, which in the opinion of the District Council is erected and maintained in an effective manner and land within the boundaries of a town shall be exempt from any such rate.

DIVISION IV.—DESTRUCTION BY OWNERS AND OCCUPIERS.

DIVISION IV.

19. Every owner and every occupier of any land shall at all times, and at his own cost and expense, destroy all vermin upon the said land, and upon the half width of all roads adjoining the same.

Duty of owners and occupiers to destroy vermin.

Ibid., s. 19.

20. (1) In order to better provide for the simultaneous destruction of vermin, the said destruction shall, within the District of every District Council, Vermin Board, and Associated Board, be simultaneously proceeded with by all owners and occupiers during the months of January, February, and March in every year.

Simultaneous vermin destruction months.

Ibid., s. 20.

1398, 1919, s. 4.

1567, 1923, s. 4.

(2) Nothing in this section shall be construed to imply that the destruction of vermin shall not be proceeded with and enforced during the remainder of the year, or that a notice under section 22 may not be given during the said simultaneous vermin destruction months.

(3) The Commissioner may, from time to time, by notice published in the *Gazette*, fix a period or periods other than the period referred

PART II.
DIVISION IV.

Vermin Act.—1931.

to in subsection (1) hereof for the simultaneous destruction of vermin within the District of any District Council, Vermin Board, or Associated Board, provided that any such substituted period or periods shall not exceed three months in the aggregate. Any such substituted period or periods may be within or outside, either wholly or partially, the said period referred to in subsection (1) hereof.

(4) Upon the publication of a notice under subsection (3) hereof the substituted period or periods fixed by the notice for the simultaneous destruction of vermin within the District therein mentioned shall be deemed to be the simultaneous vermin destruction months for that District, and the provisions of this Act in their application to the said District shall be read and construed accordingly.

Power to enter land
and search for
vermin.
1181, 1914, s. 21.

21. Every authorised person may, with or without assistants—

- (a) enter upon any land, at any time ;
- (b) search to ascertain whether any vermin are to be found upon the land ; and
- (c) remain upon the land for such time as is reasonably necessary for the purposes of such search.

Notice to owner or
occupier to destroy
vermin.
Ibid., s. 22.

22. (1) Where an authorised person finds vermin upon any land (not being Crown lands) he may, by notice in writing, require the owner or occupier of the land to forthwith destroy all vermin upon the land, and upon the half width of all roads adjoining the same.

(2) The said notice may be in the form in the Fifth Schedule.

Penalty for not
destroying vermin
during simultaneous
destruction period or
after notice.
Ibid., s. 23.
1567, 1923, s. 5.

23. (1) The owner or occupier of any land who does not—

- (a) during the simultaneous vermin destruction months in any year ; or
- (b) within the prescribed time after the service upon him of a notice under section 22,

destroy all vermin upon the said land, and upon the half width of all roads adjoining the same, shall be liable to a penalty for a first offence of not less than Two Pounds nor more than Five Pounds, and for a second offence of not less than Five Pounds nor more than Twenty Pounds, and for any subsequent offence of not less than Twenty Pounds nor more than Fifty Pounds.

(2) A complaint under this section—

- (a) shall not be laid except by an authorised person ;
- (b) may be in such of the forms No. 1 and No. 2 in the Sixth Schedule as is applicable to the case, and when in any such form shall not be questioned for want of form ;
- (c) may be amended by the Court ; and

(d) shall

*Vermin Act.—1931.*PART II.
DIVISION IV.

(d) shall be laid within six months from the expiration of the simultaneous vermin destruction months, or from the date of the service of the said notice, according to the nature of the case.

(3) In paragraph (b) of subsection (1) hereof, the expression "prescribed time" means the time prescribed for the purposes of the said paragraph by the Commissioner, by notice published in the *Gazette* and in two daily and two weekly newspapers published in South Australia, with regard to land situated within the District Council District or Vermin-Fenced District, or other area, within which the land specified in the notice is situated. A copy of the *Gazette* containing any such notice as aforesaid shall be *prima facie* evidence that the time prescribed by the notice is the prescribed time within the meaning of this section.

24. (1) Where an owner or occupier is charged with an offence under section 23 the averments contained in the complaint shall be deemed to be proved in the absence of proof to the contrary. Onus of proof.
1181, 1914, s. 24.
1567, 1923, s. 6.

(2) The said averments shall be deemed conclusively proved upon proof on behalf of the complainant of the presence of vermin upon the lands mentioned in the said complaint—

(a) where the land is within the District of a District Council or Associated Board, at any time after fourteen days from the date of the service of a notice under section 22, or from the expiration of the simultaneous vermin destruction months, according to the nature of the case :

(b) where the land is not within the District of any District Council or Associated Board, at any time after the expiration of three months from the date of service of such a notice, or from the expiration of the simultaneous vermin destruction months, according to the nature of the case.

(3) Any such averment shall be deemed to be proved as provided in subsections (1) or (2) hereof, notwithstanding that the averment may not be an averment of fact only, and notwithstanding that any evidence may be given as to the subject matter of the averment.

25. Where an owner or occupier neglects or fails to comply with a notice under section 22, an authorised person, in addition to proceeding for and notwithstanding the infliction of a penalty under section 23 hereof, may— Powers of officers on failure or neglect of owner or occupier.
1181, 1914, s. 25.

(a) enter upon the land of the owner or occupier ;

(b) use all such means, and take all such measures, and do and perform all and every such acts or things, as to him appear proper or necessary to be done to ensure the destruction of vermin upon the land and roads or parts of roads mentioned in the notice ; and

(c) remain

PART II.
DIVISION IV.

Vermin Act.—1931.

(c) remain upon, and shall have free right of ingress, egress, and regress into, over, and across the land for such period as may be necessary for destroying the vermin.

Liability of owner or occupier not commencing and continuing to comply.

Ibid., s. 26.

1567, 1923, s. 7.

26. For the purposes of section 25 an owner or occupier who—

(a) does not forthwith after the service upon him of the notice mentioned in that section commence to comply therewith ; or

(b) having so commenced, does not continue such compliance to the satisfaction of an authorised person,

shall be deemed to have neglected or failed to comply with the notice.

Cost and expenses recoverable from owner or occupier.

1181, 1914, s. 27.

1567, 1923, s. 8.

27. (1) The cost and expense incurred by an authorised person in acting under section 25 shall be a debt due by the owner or occupier of the land to the appointers of the authorised person and payable on demand, and may be recovered by action in any Court of competent jurisdiction, or in a summary way.

(2) Until the said cost and expense is paid by the owner or occupier liable to pay the same, the amount thereof shall be paid—

(a) where the land in respect of which the cost and expense is incurred is within a District Council District, by the Council of the said District, out of the general revenue thereof :

(b) where the land is within a Vermin-Fenced District, by the Board of the said District, out of the general revenue thereof :

(c) where the land is within the boundaries and limits under the control of an Associated Board, by the Board out of its general revenue :

(d) in all other cases, by the Treasurer out of the General Revenue of the State.

Power of lessee or tenant to recover proportion of expenses of destruction from lessor or landlord in certain cases.

1181, 1914, s. 28.

28. Every occupier of land alienated from the Crown who pays the cost and expense of the destruction of vermin upon land held by him as lessee or tenant for a term having less than five years to run from the date of the entry by an authorised person upon the said land under section 25, shall, in the absence of a contract to the contrary, be entitled to be repaid by his lessor or landlord so much of the cost and expenses so paid by him as would be payable for the difference between a term of five years and the time so to run of his lease or tenancy, upon the computation that the total sum paid was payable in respect of a five years term or tenancy.

Restriction on levying of distress for rent in certain cases.

Ibid., s. 29.

29. (1) No distress shall be levied upon an occupier of land by his lessor or landlord for rent due by the occupier whilst any sum remains payable by the said lessor or landlord to the said occupier under

*Vermin Act.—1931.*PART II.
DIVISION IV.

under section 28, unless the amount of the rent exceeds the sum payable by the lessor or landlord as aforesaid, and then only for the amount by which the rent exceeds the sum so payable.

(2) No assignment by a lessor or landlord whilst any such sum remains payable by him to an occupier shall defeat the right of the occupier to the payment of the said sum out of the rent of the land in respect of the destruction of vermin upon which the same is payable.

30. The following provisions shall apply where any land (other than Crown lands) is unoccupied and the owner thereof is unknown:—

Provision where
land is unoccupied.
Ibid., s. 30.
1955, 1930, s. 7.

- I. An authorised person may exercise all or any of the powers conferred by section 25, without serving a notice under section 22 :
- II. Proceedings may be taken for the recovery of the cost and expense of destroying vermin on the land, in the manner provided by this Part, without sending the notice required to be sent by section 31.

31. (1) Where the amount due and payable to a District Council, Associated Board, or Vermin Board, or to the Commissioner for the cost and expenses of destroying vermin on any land is unpaid for three months, the Council, Associated Board, Vermin Board, or Commissioner may send to the registered owner of the land a notice in the form in the Seventh Schedule, or in a form to the like effect.

Power to give
notice when cost of
destruction unpaid
for three months.
1181, 1914, s. 31.

(2) The notice shall also be published three times in the *Gazette*.

32. The notice under section 31 shall be sent by post to the registered owner of the land, or to his agent or attorney in case there is any such agent or attorney resident in the State known to the Council, Board, or Commissioner giving the notice.

Sending of notice.
Ibid., s. 32.

33. If after one month from the third publication as required by section 31 of the said notice the amount mentioned therein as being due and payable by an owner or occupier, or any portion thereof, remains unpaid, the District Council, Associated Board, Vermin Board, or Commissioner (as the case may be)—

Power to let land
for payment of cost
of destruction.
Ibid., s. 33.

(a) may let the land mentioned in the notice, or any part thereof, for a year, and so on from year to year, until the said amount or portion and all other amounts made payable under this Act are paid and discharged ; and

(b) may receive and retain the rents and apply the same in payment—

- i. in the first place, of all costs of and attending the notice, the publication thereof, and the letting ; and

ii. in

- II. in the next place, in and towards the payment of the cost and expense of the destruction and suppression of vermin on the land mentioned in the notice, including the cost and expense incurred at the time of the first publication of the notice and any cost and expense incurred either in the destruction or suppression of vermin on the said land up to the time of the letting, or in any way whatsoever connected with non-payment of the amount at any time recoverable by the District Council, Associated Board, Vermin Board, or Commissioner (as the case may be), or for any Act done or performed under the provisions hereof,

until the owner or occupier has paid and discharged the same ; and

(c) shall hold any surplus of rent for the owner of the land.

Power to sell land for payment of cost of destruction on petition to Supreme Court.

Ibid., s. 34.

34. (1) Instead of letting the land under section 33 the District Council, Associated Board, Vermin Board or Commissioner (as the case may be) may apply by petition to the Supreme Court for a sale of all or any part of the land.

(2) The petition shall not, where the owner or occupier is unknown, be presented until after one month from the third publication of the notice as required by section 31.

(3) The petition shall not, where the owner or occupier is known, be presented until after the expiration of six months from the third publication as aforesaid of the notice and service of a copy thereof or to the like effect upon the owner or occupier, or his authorised or generally recognised agent in the State, by delivering the same at or sending it by post addressed to the owner or occupier, or agent, at his last known place of abode in the State.

(4) The Court, on being satisfied by affidavit or otherwise that the moneys mentioned in the notice are lawfully due, and were owing at the time of the first publication of the notice, and that all things required by this Act to be done have been done, may make an absolute order in the first instance, or may grant a rule, calling upon the owner or occupier, if known, or all whom it may concern, if the owner or occupier is unknown, to show cause why an order should not be made for the sale by public auction of the land comprised in the petition, or so much thereof as may be sufficient to pay—

(a) the cost and expense incurred at the time of the first publication of the notice :

(b) the cost and expense incurred in the destruction of vermin on the land up to the time of the application for sale :

(c) all

Vermin Act.—1931.PART II.
DIVISION IV.

- (c) all costs and expenses of and attending the notice, the application, and the sale :
- (d) all other costs, charges, and expenses for any Act done or performed by the petitioners, or by their authority, for carrying out the provisions of this Part.
- (5) Unless good cause is shown to the contrary within the time fixed by the rule, the Court shall order—
- (a) the sale of the land in manner aforesaid ;
- (b) payment out of the proceeds of the sale of the said costs, charges, and expenses in preference to any mortgage or other security on the land ; and
- (c) that a conveyance, or if the property is under the provisions of the Real Property Act, 1886, a memorandum of transfer (which the Registrar-General is hereby directed to register) be executed by the Master of the Supreme Court in a form to be approved by a Judge. No. 390 of 1886.
- (6) The said conveyance, or the registration of the said memorandum of transfer (as the case may be), shall vest an indefeasible estate in fee simple in the said land in the purchaser, his heirs and assigns, free from all encumbrances.
- (7) The balance arising from the proceeds of any such sale shall remain and be subject to any future or other order of the Court for the behoof of the persons interested therein.
- (8) Where lands belonging to different owners are included in any notice under section 31, the same may be included in one petition for sale, and the Court may make such orders as to the apportionment of the costs and expenses of and incidental to the sale of the lands or any part thereof, as are deemed just.
- 35.** (1) Where any money payable under this Part by any owner or occupier to a District Council, Associated Board, or Vermin Board, or to the Commissioner (as the case may be) remains due and unpaid for the space of one month after notice in writing to pay the same has been given to the owner or occupier, any person by the said District Council, Associated Board, Vermin Board, or Commissioner thereunto authorised may at any time thereafter so long as any money remains so unpaid, without any warrant, enter upon any land of the said owner or occupier, and distrain the goods, chattels, and effects found thereon for the amount remaining due and unpaid, Power to levy distress.
Ibid., s. 35.
- (2) If the amount for which the distress is levied, together with all reasonable costs of the notice, entry, and distraint, is not paid within five days after the levy, then the said distress, or so much thereof as is sufficient to pay the amount remaining unpaid and costs, may be sold.
- (3) Any surplus remaining after payment of the said amount and costs, and the costs of and incidental to the sale, shall be returned to the owner of the goods, chattels, and effects distrained.

36. Nothing

PART II.
DIVISION IV.

Vermin Act.—1931.

Owner or occupier
not bound to clear
travelling stock
reserve, or destroy
rabbits in cages.
Ibid., s. 36.
1955, 1930, s. 8.

36. Nothing in this Part contained shall be construed to render it the duty of an owner or occupier of land—

- (a) to destroy vermin upon a dedicated travelling stock reserve or Crown lands used as a travelling stock road which is within the boundaries of, or adjoining, the land of the owner or occupier :
- (b) to destroy rabbits kept in any cage or enclosure on his land.

In this section—

“Cage” means a cage, hutch, box, or similar erection which is completely rabbit-proof :

“Enclosure” means any land not exceeding six hundred square feet in area which is completely enclosed by a rabbit-proof fence and which is completely rabbit-proof.

Power of occupier
to lay poison for
destruction of
vermin.
1181, 1914, s. 37.

37. (1) Subject to subsection (2) hereof, any occupier of land, for the purpose of carrying out his duties under this Act with regard to the destruction of vermin, may lay poison on his land.

(2) No poison shall be laid under the provisions of this section unless notice of the poison being laid is conspicuously exhibited on the land, and no poison shall be so laid within one hundred yards of any public road or way.

Power of Com-
missioner to lay
poison for destruc-
tion of vermin.
1528, 1922, s. 3.

38. (1) Subject to subsection (2) hereof, for the purpose of the destruction of vermin, the Commissioner, or any person authorised by the Commissioner, may lay poison or set traps on any Crown lands not within a District Council District or a Vermin-Fenced District.

(2) No poison shall be laid pursuant to the provisions of this section unless notice of the poison being laid is conspicuously exhibited on the land whereon the same is laid, and no poison shall be so laid within one hundred yards of any public road or way.

Immunity of
certain persons.
1181, 1914, s. 38.
1567, 1923, s. 9.

39. No authorised person or Government inspector shall be deemed a trespasser, or be liable for any damage occasioned by him in the exercise of the powers, discretions, and authorities, or any of them, by this Part conferred upon him, unless the damage is occasioned by or under the authority of the said person wilfully and without necessity.

DIVISION V.

DIVISION V.—DESTRUCTION ON BREAKWIND RESERVES IN
PINNAROO RAILWAY DISTRICT AND ON DRAINAGE LANDS.

Destruction of
vermin on break-
wind reserves.
1181, 1914, s. 39.
1955, 1930, s. 9.
No. 831 of 1903.

40. (1) The owner and the occupier of any land adjoining any land within the Pinnaroo Railway District reserved by the Surveyor-General as a breakwind (whether the land so reserved is or is not within any of the hundreds mentioned in section 13 of the Pinnaroo Railway Act) shall at all times and at his own expense destroy all vermin upon the said breakwind reserve, and upon the half width of any road adjoining the said reserve.

(2) When

*Vermin Act.—1931.*PART II.
DIVISION V.

(2) When any land is separated from any such breakwind reserve only by a road, the owner or occupier of the land shall, at all times and at his own expense, destroy all vermin upon the full width of the road, and upon the breakwind reserve, and upon the half width of any other road adjoining the reserve.

(3) The obligation imposed by this section on the owner or occupier of land shall not apply in any case where the land adjoining the breakwind reserve on the side thereof remote from the first-mentioned land, or only separated therefrom by a road, is Crown lands (which term in this subsection does not include land vested in the South Australian Railways Commissioner).

(4) The obligation imposed by this section shall apply with respect to the whole width of a breakwind reserve, and with respect to so much of the length thereof as adjoins the land of the owner or occupier bound by this section, or as is separated therefrom only by a road.

(5) When the owners or occupiers of lands on different sides of a breakwind reserve, or only separated therefrom by a road or roads, are bound by this section to destroy vermin on the reserve, or the reserve and road or roads, and the owner or occupier of the land on one of the said sides destroys the vermin, he may, by action in any Court of competent jurisdiction or summarily, recover a portion of the costs and expenses of the destruction thereof from the owner or occupier of the land on the other of the said sides.

The portion so recoverable shall be determined according to the respective liabilities of the owners or occupiers under this section in respect of the reserve, or reserve and road or roads, or the part or parts thereof whereon the vermin have been so destroyed.

(6) In this section the expression "Pinnaroo Railway District" means the area enclosed by the outer edge of the blue line shown on the plan in the Second Schedule to the Pinnaroo Railway Act. No. 831 of 1903.

41. (1) Every owner and every occupier of any land adjoining any land—

- (a) reserved under the Crown Lands Act, 1915, or the Crown Lands Act, 1929, for drainage purposes;
- (b) vested in His Majesty the King, or in the South-Eastern Drainage Board; or
- (c) vested in any District Council by virtue of the provisions of the South-Eastern Drainage Act, 1878, or the South-Eastern Drainage Act Amendment Act, 1908,

Destruction of
vermin on drainage
lands.

1398, 1919, s. 9.
1631, 1924, s. 6 (1).
2000, 1931, s. 3.

on which is situated any drain or drainage works within the meaning of the South-Eastern Drainage Act, 1926 (hereinafter called "drainage lands"), shall, at all times, and at his own expense, destroy all vermin upon the said drainage lands, and on the half width of any road adjoining the said drainage lands.

(2) When any land is separated from any such drainage lands by a road only, the owner or occupier of the land shall, at all times, and

and at his own expense, destroy all vermin upon the full width of the road, and upon the said drainage lands, and upon the half width of any other road adjoining the drainage lands.

(3) The obligation imposed by this section on the owner or occupier of land shall not apply in any case where the land adjoining the drainage lands on the side thereof remote from the first mentioned land, or separated therefrom by a road only, is Crown lands.

(4) The obligation imposed by this section shall apply with respect to the whole width of drainage lands, and with respect to so much of the length thereof as adjoins the land of the owner or occupier bound by this section, or as is separated therefrom by a road only.

(5) When the owners or occupiers of lands on different sides of drainage lands, or separated therefrom by a road or roads only, are bound by this section to destroy vermin on the drainage lands, or on the drainage lands and road or roads, and the owner or occupier of the land on one of the said sides destroys the vermin, he may, by action in any Court of competent jurisdiction, or summarily, recover a portion of the costs and expenses of the destruction thereof from the owner or occupier of the land on the other of the said sides.

The portion so recoverable shall be determined according to the respective liabilities of the owners or occupiers under this section in respect of the drainage lands, or drainage lands and road or roads, or the part or parts thereof whereon the vermin have been destroyed.

Notice to owner or occupier to destroy vermin.

1181, 1914, s. 40.
1398, 1919, s. 10.

42. When an authorised person finds vermin upon any such breakwind reserve or road as mentioned in section 40, or upon any such drainage lands or road as mentioned in section 41, he may, by notice in writing, require any person bound by the said sections to destroy the vermin to forthwith destroy all vermin thereon, or on the part or parts thereof in respect of which he is so bound (as the case may be).

Penalty for not destroying vermin during simultaneous destruction period or after notice.

1181, 1914, s. 41.
1398, 1919, s. 11.
1567, 1923, ss. 10 and 14.
1955, 1930, ss. 10 and 25.

43. (1) The owner or occupier of any land who, being bound by section 40 to destroy the vermin on a breakwind reserve, or on a breakwind reserve and any road or roads, or being bound by section 41 to destroy the vermin on any drainage lands or on drainage lands and any road or roads, does not—

(a) during the simultaneous vermin destruction months fixed by or pursuant to section 20 in any year; or

(b) within the prescribed time after the service upon him of a notice under section 42,

destroy all vermin on the breakwind reserve, or on the breakwind reserve and road or roads, or on the drainage lands, or on the drainage lands and road or roads, or on the part or parts thereof in respect of which he is so bound (as the case may be), shall be liable to a penalty for a first offence of not less than Two Pounds nor more than Five Pounds, and for a second offence of not less than Five Pounds nor more than Twenty Pounds, and for any subsequent offence of not less than Twenty Pounds nor more than Fifty Pound

(2) The

Vermin Act.—1931.

PART II.
DIVISION V.

(2) The provisions of subsection (2) of section 23 shall apply to a complaint under this section, except that the complaint may be in such of the forms No. 3 and No. 4 in the Sixth Schedule as is applicable to the case or in such of the said forms, *mutatis mutandis* as is applicable to the case, and when in such form shall not be questioned for want of form.

(3) This section shall be read as if the provisions of subsection (3) of the said section 23 and the provisions of section 24 were repeated in this section.

PART III.

VERMIN-FENCED DISTRICTS.

DIVISION I.—INTERPRETATION.

PART III.

DIVISION I.

44. In this Part—

“Public notice” means notice given by advertisement in the *Gazette*, and by posting handbills, written or printed, or produced by mechanical process, on every post office in the District and on every other place appointed by the Board, by by-law or otherwise, as a place for posting notices: Provided that, in any case where posting as aforesaid on post offices is not permitted by the Commonwealth postal authorities, public notice shall be deemed complete without posting thereon:

Interpretation
1181, 1914, s. 42.
1249, 1916, s. 4.
1955, 1930, s. 11.
1990, 1930, s. 4.

“Ratable property” means all lands, tenements, and hereditaments (including Crown lands, whether occupied or unoccupied) within the limits of a District:

“Ratepayer” means the owner or occupier of ratable property, or the owner of unoccupied ratable property, or the Director of Lands in respect of ratable property belonging to the Crown, whether occupied by the Crown or unoccupied.

DIVISION II.—CONSTITUTION OF VERMIN-FENCED DISTRICTS AND VERMIN BOARDS, AND SUSPENSION AND ABOLITION OF BOARDS.

DIVISION II.

45. (1) The Governor may, by proclamation—

(a) upon the petition of the holders representing one-half of the ratable property (exclusive of unoccupied Crown lands) within the boundaries of the area mentioned in the petition, constitute that area, not being lands within a Municipality and not being already a Vermin-Fenced District, a Vermin-Fenced District for the purposes of this Act:

Power of Governor
to constitute new
Vermin-Fenced
Districts.
1181, 1914, s. 43.

(b) assign a name to the District and fix the boundaries thereof:

(c) declare that any lands shall cease to be a Vermin-Fenced District or portion of a Vermin-Fenced District:

(d) vary the boundaries of a District.

(2) No

PART III.
DIVISION II.

Vermin Act.—1931.

(2) No proclamation constituting a District, or varying the boundaries of a District, shall be made unless a plan of the proposed District or of the proposed alteration of the District, showing the proposed boundaries and the amount of freehold lands, lands leased by the Crown, and unleased lands belonging to the Crown, comprised within the same, is laid before Parliament and is approved by resolution of both Houses thereof.

(3) No owner holding less than a quarter of a square mile of land within the proposed District shall be entitled to take any part in relation to the formation of the District.

(4) Notwithstanding anything in this section, no area shall be declared a Vermin-Fenced District as aforesaid unless there are, at the time of publication of the proclamation, at least three rate-payers holding ratable property (other than ratable property belonging to the Crown) situated within the area.

Alteration of
boundaries.
Ibid., s. 44.
1869, 1928, s. 4.

46. The Governor may, by proclamation—

- (a) in case a Board has erected a vermin fence or a dog-proof fence outside the boundaries of the District ; or
- (b) in case it is impracticable or would be very difficult to erect a vermin fence or a dog-proof fence on the boundaries of the District,

extend the boundaries of the District so as to include the fence already erected, or to include the land on which it is proposed that the fence shall be erected, and,

- (c) in case portion of the District is situated outside of the vermin fence or dog-proof fence erected by the Board,

sever the said outside portion from the District.

Apportionment of
property and adjust-
ment of rights.
1181, 1914, s. 45.

47. The Governor may, by proclamation, make any apportionment of property or adjustment of rights and liabilities as between two or more Districts, which is rendered necessary or expedient owing to the alteration of the boundaries of any District or Districts.

Contribution for
fences already
erected.
Ibid., s. 46.
1869, 1928, s. 4.
1955, 1930, s. 12.

48. (1) Where any portion of the boundaries of a District declared under Part III. of the Vermin Act, 1905, or constituted under Part III. of the Vermin Act, 1914, or under this Part of this Act (hereinafter in this section called "the new District") consists of portion of the vermin fence or dog-proof fence of a previously existing District, the following provisions shall apply :—

- i. The Board of the new District shall pay to the Board of the previously existing District one-half of the value, at the time of the publication of the proclamation constituting the new District, of the said portion of the said fence :

ii. The

*Vermin Act.—1931.*PART III.
DIVISION II.

- ii. The amount so to be paid, unless agreed upon by the two Boards, within three months after notice given in writing by either Board to the other requiring that the said amount shall be fixed, shall be fixed by the Commissioner by order published in the *Gazette* :
- iii. The amount so agreed or fixed may be paid in twenty equal yearly instalments, together with simple interest on the balance for the time being remaining unpaid at the rate per centum per annum paid by the Board of the previously existing District for any money borrowed by it in respect of the said fence :
- iv. The first of the said instalments shall be paid within twelve months from the date when the amount to be paid is agreed upon or fixed as aforesaid : and one of the said instalments shall be paid in every year thereafter until the whole amount is paid :
- v. There shall be set off against the amount which the Board of the new District is required by this section to pay to the Board of the previously existing District—
- (a) one-half of any amount which any occupier of land within the new District has paid pursuant to section 115 to the Board of the previously existing District in respect of the said vermin fence or dog-proof fence ; and
- (b) one-half of any amount which the Board of the previously existing District has paid pursuant to subsection (2) of this section to any lessee of land within the new District in respect of any fence forming the whole or any portion of the boundary fence in question.

(2) Where any portion of the boundaries of a District constituted as mentioned in subsection (1) hereof consists of portion of a vermin proof or other fence, the property in whole or in part of a lessee, the Board shall pay to the lessee one-half of the value of his interest in the fence at the time when the District was constituted, the said price to be fixed by mutual agreement, or, failing that, by arbitration pursuant to the Arbitration Act, 1891. Every such fence shall upon payment as aforesaid vest in the Board.

No. 510 of 1891.

49. The following provisions shall apply upon the constitution of a new District under section 45 :—

Appointment of
Boards and auditors.
1181, 1914, s. 47.
1955, 1930, s. 13.

- i. The Governor shall appoint four persons to be the Vermin Board of the District :
- ii. One of the said persons shall be a Government officer :
- iii. Where possible the other members of the Board shall be ratepayers, or persons residing within the District who are the representatives within the District of ratepayers :
- iv. The

PART III.
DIVISION II.

Vermin Act.—1931.

- iv. The Governor may also appoint one of the members to be Chairman of the Board :
- v. The Governor may also appoint two auditors for the District :
- vi. The Government officer shall hold office during the pleasure of the Governor and shall not be subject to retirement by effluxion of time :
- vii. The other members of the Board and the auditors shall retain office until after the first annual election after the constitution of the District :
- viii. The Board shall have and exercise all the powers, duties, and functions of a Vermin Board under this Act.

Extraordinary
vacancies on Board.
1181, 1914, s. 48.

50. (1) Any extraordinary vacancy on a Board (except in the case of the Government officer) shall be filled by the appointment by the Board of a person to be a member in the place of the member whose seat has become vacant.

(2) The member so appointed shall hold office until after the first annual election after his appointment.

Power to appoint
non-ratepayers upon
Board.
Ibid., s. 49.

51. In case there are only three ratepayers in a Vermin-Fenced District, and one of them resigns his position as a member of the Board, the Governor may appoint a person who is not a ratepayer of the District to act upon the Board.

Board to be a body
corporate.
Ibid., s. 50.

52. (1) The Vermin Board for any District continued by this Act shall continue to be, and the Vermin Board for any District constituted under this Act shall be, a body corporate under the title of "The Vermin Board of the District of _____", the blank being filled in, in the case of a District continued by this Act, with the name assigned to the District by or under the Vermin Act, 1905, or the Vermin Act, 1914, and in the case of a District constituted under this Act, with the name assigned thereto by the Governor in the proclamation whereby it is constituted.

(2) Every such body corporate shall continue to have or shall have perpetual succession and a common seal, and under its corporate name shall continue to be or shall be capable in law of suing and being sued, and of doing and suffering, subject to this Act, all such other acts and things as bodies corporate may by law do and suffer.

(3) The corporate name of the Board shall be part of the seal of the Board.

(4) The seal shall be kept at the Vermin Board Office.

Suspension or
abolition of Boards.
Ibid., s. 51.

53. (1) If it appears to the Governor that any Board—

(a) refuses or neglects to perform the duties and functions imposed and conferred upon the Board by this Act ; or

(b) refuses or neglects to declare or levy any rates which the Board should declare or levy ; or

(c) makes

*Vermin Act.—1931.*PART III.
DIVISION II.

- (c) makes default in the due payment of an instalment of principal and interest due on a loan ; or
- (d) has misappropriated or has appropriated for any purpose not contemplated by this Act any of the moneys at the disposal of the Board, or any part of the revenue of the Board,

the Governor, by proclamation, may suspend the powers and functions of the Board for such time as he thinks fit or proper, or may abolish the Board.

(2) The word "loan" in subsection (1) of this section shall be read as applying to—

- (a) loans under Division III. of Part V. of this Act ; and
- (b) loans under Division III. of Part VI. of the Vermin Act, 1914 ; and
- (c) loans under Division I. of Part VI. of the Vermin Act, 1905, whether under that Division as passed or read as provided by section 5 of the Vermin Act Amendment Act, 1911,

as well as to—

- (d) loans under Division X. of this Part ; and
- (e) loans under Division X. of Part III. of the Vermin Act, 1914 ; and
- (f) loans under Division IX. of Part III. of the Vermin Act, 1905.

54. When the powers and functions of a Board are suspended, or a Board is abolished, the Governor may, by proclamation, authorise the Commissioner to exercise all the powers, authorities, functions, and duties of that Board during the suspension of the Board, or until a new Board is appointed.

Effect of abolition and suspension.
Ibid., s. 52.

55. All property, real and personal, and all powers, authorities, immunities, rights, privileges, functions, obligations, and duties vested in or imposed on a Board by any means whatsoever shall, by force of this Act, be transferred to and vested in the Commissioner while the powers and functions of the Board are suspended, or upon the abolition of the Board.

Vesting of property in Commissioner.
Ibid., s. 53.

56. The following provisions shall apply when a Vermin-Fenced District ceases to be a Vermin-Fenced District :—

Vesting of property on extinction of Board.

- i. The Board of the District shall be deemed to be abolished :
- ii. So much of any fence erected or purchased by the Board, as is on the land of a lessee shall become the property of the lessee, upon payment to the Crown by the lessee
- of

Ibid., s. 54.
1955, 1930, s. 14.

PART III.
DIVISION II.

Vermin Act.—1931.

of the then value of the portion or portions of the fence on his land, less the amount paid by the lessee to the Board on account of the cost thereof (but not including any amounts paid pursuant to section 116) :

- III. The moneys so paid to the Crown by lessees shall, after deducting proper expenses of collection, be divided amongst the persons who were ratepayers of the District during the year prior to the abolition of the Board *pro rata* according to the number of square miles of land held by them respectively within the District and in respect of which said land the ratepayer was during the said period required pursuant to this Act to pay rates to the Board.

DIVISION III.

Qualification for membership of Board.

1181, 1914, s. 55.

DIVISION III.—MEMBERS OF A BOARD.

57. (1) Subject to subsection (2) hereof, the following persons are qualified to be and continue as members of a Board :—

- I. Every male ratepayer of the District of the Board who has attained the age of eighteen years :
- II. Any person who resides within the District of the Board who is the representative of any ratepayer of the District of the Board, has attained the said age, and is nominated in writing signed by the said ratepayer :
- III. Any officer of or a shareholder in a company which is a ratepayer of the District of the Board.

(2) No person shall be qualified to be or continue to be a member of a Board if he—

- (a) is an undischarged bankrupt :
- (b) holds the office of treasurer or a place of profit in the gift of the Board :
- (c) directly or indirectly participates or is interested in any contract (except for advertisements and printing) with or employment under the Board.

(3) No person shall be disqualified from being or continuing to be a member of a Board by reason of the receipt by him of travelling expenses incurred in pursuance of and paid under the authority of a resolution of the Board.

How vacancy occasioned.
Ibid., s. 56.

58. The following acts and events shall cause a vacancy in the office of a member of a Board :—

- I. Death or lunacy of the member :
- II. Bankruptcy of the member, or the execution by him of a statutory deed of assignment for the benefit of his creditors, or compounding with his creditors for less than Twenty Shillings in the Pound :
- III. The

*Vermin Act.—1931.*PART III.
DIVISION III.

- III. The conviction of the member of felony :
- IV. Absence of the member from the State, without leave of the Board, during the holding of three consecutive ordinary meetings, or failure to attend the meetings of the Board for three consecutive ordinary meetings without sufficient cause, followed, in either case, by a resolution passed by the Board within three weeks after the last of such three consecutive ordinary meetings, declaring the office vacant, which resolution the Board may pass, but is not bound to pass :
- V. Notice of any disqualification of the member given by the member or by some person on his behalf by posting or delivering the same to the Chairman, or, if there is no Chairman, to the Commissioner :
- VI. Resignation of the member, by notice posted or delivered as aforesaid :
- VII. Retirement of the member, by rotation, as provided by this Act :
- VIII. The judgment or order of any Court of competent jurisdiction declaring the office of the member vacant.

59. At the conclusion of the first annual election after the constitution of a new District, all the members of the Board (except the Government officer) shall retire.

Retirement of members of new Boards.
Ibid., s. 57.

60. At the conclusion of every annual election, after the first, in the case of a new District, and at the conclusion of every annual election, in the case of any other District, the following provisions shall apply :—

Retirement of members of other Boards.
Ibid., s. 58.

- I. One of the members (not being the Government officer) shall retire :
- II. The member to retire shall be the member (if any) who holds office by appointment of the Board, or the member who has been longest in office without re-election, and, when the member to retire cannot thus be ascertained, lots shall be drawn between those who have been an equal time in office without re-election to decide which of them shall retire, and the retirement shall take place accordingly :
- III. The Chairman shall in no case be required to draw lots ; but the other member or members with whom it would have been necessary, but for his office as Chairman, that he should draw lots, shall retire, or shall draw lots between them to decide which of them shall retire.

61. (1) All drawing of lots by members of a Board to decide the order of retirement shall be had before the first publication of the notice under subdivision I. of section 76.

Drawing of lots before notice of nomination.
Ibid., s. 59.

(2) If the members of the Board fail to draw lots to decide the order of retirement within the time prescribed by subsection (1) hereof, the Chairman, or a Justice resident in the District, on the request in writing of a member of the Board, or of three ratepayers of the District, shall, in the presence of three or more of such ratepayers, draw lots to decide which of the members of the Board shall retire; and the Chairman or Justice (as the case may be) shall thereupon declare and give public notice under his hand of the name of the member who is to retire, and he shall retire accordingly.

Retiring member of a Board to hold office until successor appointed.

Ibid., s. 60.

Filling of vacancies existing at the annual election.

Ibid., s. 61.

62. Any member of a Board required to retire under this Act shall be deemed to hold office until his successor is appointed or elected.

63. (1) When, at the time of the first publication of the notice under subdivision 1. of section 76, there are vacancies on a Board, and no more members are required to retire at the conclusion of the election for that year than there are seats then vacant, there shall be no need for any retirement of members, but the vacancies so existing shall be filled at the said election.

(2) If any vacancy or vacancies exist at the time of the first publication of the notice mentioned in subsection (1) hereof, every member whose seat is so vacant shall be taken to be a person bound to retire at the annual election; and every such vacancy shall be filled at the annual election, and any other retirements shall be determined in manner herein provided.

Election and resignation of Chairman.

Ibid., s. 62.

64. (1) At the first meeting of the Board held after any annual election the members present shall elect one of their number to be Chairman of the Board.

(2) If there is an equal number of votes cast for two or more members, the Chairman shall be chosen by lot between those members having an equality of votes.

(3) The omission to elect a Chairman as aforesaid shall not prevent the Board from making the election at a future meeting.

(4) The Chairman may resign his office at any time, and a vacancy in the office of Chairman may be filled up at any meeting of the Board.

Retiring Chairman and members eligible for re-election.

Ibid., s. 63.

Immunity of members.

Ibid., s. 64.

65. A member of a Board or the Chairman of a Board retiring from or ceasing to hold office, but duly qualified, shall be eligible for re-election.

66. (1) No member of a Board shall be subject to be sued or prosecuted by any person whomsoever, nor shall the body, goods, or lands of a member of a Board be liable to any execution of any legal process, by reason of any contractual or other instrument entered into by the Board, or by reason of any other lawful act done by the Board in the execution of any of its powers.

(2) Every

*Vermin Act.—1931.*PART III.
DIVISION III.

(2) Every member of a Board, his heirs, executors, and administrators, shall be indemnified by the Board for all payments made, or liabilities incurred, in respect of any acts done by him, and of all losses, costs, and damages which he may incur, in the *bona fide* execution of the powers granted to him by this or any other Act.

DIVISION IV.—AUDITORS.

DIVISION IV.

67. (1) The auditors appointed by the Governor shall retire at the conclusion of the first annual election after the constitution of the Board.

Election and retirement of auditors.
Ibid., s. 65.

(2) At the first annual election two auditors for the District shall be nominated and elected by the ratepayers in like manner as members of a Board are nominated and elected.

(3) At every subsequent annual election one auditor shall retire from office, and the auditor to retire shall be the one who has held office the longer without re-election, and if both have held office for the same length of time, the auditor to retire shall be decided by lots, to be drawn by the Chairman before notice is given of the day for the nomination of auditors; and if the Chairman fails to draw lots, both auditors shall retire.

68. (1) The qualifications and disqualifications for the office of auditor shall be the same as in the case of a member of a Board except that—

Qualification of auditors.
Ibid., s. 67.

(a) an auditor need not be a ratepayer of the District; and

(b) no member of the Board of the District shall be an auditor for the District.

(2) An auditor who is qualified to be a member of a Board may be elected a member, and he shall thereupon cease to be an auditor.

69. Any of the following acts and events shall cause a vacancy in the office of an auditor :—

Disqualification of auditors.
Ibid., s. 68.

- I. Death or lunacy of the auditor :
- II. Bankruptcy of the auditor, or the execution by him of a statutory deed of assignment for the benefit of his creditors, or compounding with his creditors for less than Twenty Shillings in the Pound :
- III. The conviction of the auditor of felony :
- IV. Absence of the auditor from the State at the time at which a periodical audit is appointed to be held, or non-attendance at an audit after fourteen days notice has been given to the auditor of the time and place appointed for holding the same :
- v. Election of the auditor as a member of the Board :
- vi. Resignation

PART III.
DIVISION IV.

Vermin Act.—1931.

VI. Resignation of the auditor by notice posted or delivered to the Chairman, or, if there is no Chairman, to the Commissioner :

VII. The judgment or order of a Court of competent jurisdiction declaring the office vacant :

VIII. If the auditor is concerned, directly or indirectly, in a contract or dealing with the Board other than his employment as auditor.

Extraordinary vacancies in office of auditor.

Ibid., s. 69.

70. (1) Any extraordinary vacancy in the office of auditor may be filled by appointment by the Governor.

(2) An auditor so appointed shall hold office only until the annual election next after his appointment.

(3) If only one of the auditors has been so appointed, he shall be the auditor to retire under section 67, and the other shall continue in office unless he has acted as auditor continuously for the space of two years.

Auditing accounts.
Ibid., s. 70.

71. (1) The auditors shall forthwith after the half-yearly balancing of accounts, in accordance with this Act, audit the accounts of the Board for the half-year preceding the said half-yearly balance.

(2) The Board shall cause to be laid before the auditors the said accounts, together with proper vouchers, and all books, papers, and writings in the custody or power of the Board relating thereto.

(3) The said accounts, if found correct, shall be signed by the auditors in token of their allowance thereof.

Advertising of balance-sheet.
Ibid., s. 71
2017, 1931, s. 2.

72. The Board shall publish the half-yearly balance-sheet once in the *Gazette* within one month after the auditors have signed the same.

Power of auditors to refuse to allow persons to be present at auditing of accounts.

1181, 1914, s. 72.

73. The auditors may refuse to allow any person to be present at the audit of the accounts.

DIVISION V.

DIVISION V.—ELECTIONS.

Voters.

Ibid., s. 74.

1249, 1916, s. 4.

1990, 1930, s. 4.

74. The following provisions as to voters shall apply to all elections of members of a Board or auditors :—

- I. As regards a District which is within the limits of a District Council District the Board for the District shall, not less than one month prior to the election, prepare an alphabetical list of ratepayers entitled to vote for the election of members of the Board for the District, with the number of votes to which each ratepayer is entitled set opposite his name, and shall send a notice to each individual ratepayer showing the number of votes to which he is entitled :

II. As

*Vermin Act.—1931.*PART III.
DIVISION V.

- II. As regards a District which is not within the limits of a District Council District the said list shall be prepared by the Commissioner, and shall be published in the *Gazette* not less than one month prior to the election :
- III. Every ratepayer shall be entitled to one vote for every fifty square miles, or part of fifty square miles, of ratable property up to two hundred square miles, and one additional vote for every two hundred square miles, or part of two hundred square miles, over the first two hundred square miles :
- IV. The Director of Lands shall, in writing, nominate a person to vote in respect of ratable property belonging to the Crown :
- V. Every ratepayer of the full age of eighteen years whose name appears in the list of ratepayers may vote, provided his rates have been duly paid as required by section 75 :
- VI. In case of joint tenancy or tenancy in common, one person only shall vote, unless the land exceeds fifty square miles in area, and then one joint tenant, or tenant in common as aforesaid, may vote for each additional fifty square miles, or for any part thereof, up to two hundred square miles, and one joint tenant or tenant in common may vote for each additional two hundred square miles, or part of two hundred square miles ; and joint tenants or tenants in common entitled to vote may vote in the order in which they tender their votes until votes have been taken for the whole area :
- VII. No owner holding less than a quarter of a square mile of land within the district shall be entitled to vote.

75. (1) No ratepayer shall vote until he has paid all rates declared six months previously, and which were then payable by him in respect of the property for which he claims to vote.

Rates to be paid prior to voting. 1181, 1914, s. 75.

(2) Any ratepayer may object to a person attempting to vote if such rates have not been paid.

(3) The secretary shall post a list of all ratepayers who owe any such rates at every polling-place, but the failure to post such a list shall not invalidate the election.

76. The following provisions as to elections shall apply to all Districts :—

Provisions as to elections. *Ibid.*, s. 76.

- I. The Board shall, by notice published in the *Gazette* for four consecutive weeks, appoint a time and place when and where written nominations for members and auditors shall be received :
- II. Any such notice and nominations may be in the forms No. 1 and No. 2 in the Eighth Schedule :

III. The

- III. The time appointed to receive nominations shall be not later than six weeks after the annual meeting of the Board for the current year :
- IV. The Board shall appoint a Returning Officer, not being a candidate, to preside at the nomination and election of members and auditors :
- V. The Returning Officer shall attend at the time and place appointed for receiving nominations, and shall cause the nominations to be opened and read aloud :
- VI. If no more persons are nominated as members or auditors (as the case may be) than are required to be elected, the Returning Officer shall forthwith declare the persons nominated to be elected :
- VII. If a greater number are nominated than are required to be elected, the proceedings shall be adjourned to a day, being not less than fourteen days nor more than twenty-eight days after the adjournment, when the votes of the ratepayers shall be taken :
- VIII. Ratepayers may vote in person or by proxy :
- IX. A proxy shall be appointed in the form No. 3 in the Eighth Schedule :
- X. A proxy shall vote by filling in and signing a voting-paper in the form No. 4 in the Eighth Schedule, and delivering the same to the Returning Officer at the time appointed for voting, together with his appointment :
- XI. A ratepayer voting in person shall fill in and sign a voting-paper and hand the same to the Returning Officer as aforesaid :
- XII. For the purpose of voting every ratepayer shall be entitled to the number of votes prescribed by subdivision III. of section 74 :
- XIII. In case of equality of votes, the Returning Officer shall have a casting vote in addition to any votes he may have as a ratepayer :
- XIV. The Returning Officer shall announce the result of the voting, and shall forthwith certify the same to the Commissioner.

Failure of elections.
Ibid., s. 77.

77. When an election fails wholly or in part to be made as provided by this Act, or when an election having been made, afterwards becomes wholly or in part void, the Governor may appoint the members or auditors of the Board required to be elected.

Notice of election.
Ibid., s. 78.

78. The Board shall, within forty-eight hours after the election of a person to an office in the District, cause to be delivered or posted to such person a notice informing him of his election, and within fourteen days of the election shall insert a notice thereof in the *Gazette*.

79. If

*Vermin Act.—1931.*PART III.
DIVISION V.

79. If the Board fails to proceed to an election for the space of twenty-one days from the last day on which the election is required by this Act to be held, a Justice or a Special Magistrate may, upon the request in writing of three ratepayers of the District, do every act required to be done for holding the election.

Holding of election where Board fails to hold election.
Ibid., s. 79.

DIVISION VI.—MEETINGS OF A BOARD AND COMMITTEES
THEREOF.

DIVISION VI.

80. The Board shall have a suitable office for transacting the business of the District, to be called the Vermin Board Office for the District of _____

The Vermin Board Office.
Ibid., s. 73.

81. (1) Meetings of the Board need not be held within the District.

Meetings of Vermin Board.
Ibid., s. 80.

(2) The Board may, from time to time, fix the place where meetings shall be held, and may adjourn any meeting to any other place.

82. (1) The Board shall appoint a person of full age, who is not a member of the Board or an auditor, to be Secretary to the Board.

Secretary.
Ibid., s. 81.
1955, 1930, s. 15.

(2) Any member of the Board, or other person appointed as provided by section 92 may perform the duties of the Secretary in his absence.

83. (1) The annual meeting of the Board shall be held at the Vermin Board Office, on such day (subject to the provisions of this section) and at such hour as the Board determines.

Annual meeting.
1181, 1914, s. 82.

(2) As regards a Board continued by this Act, the meeting shall be held in the month in which the annual meeting was held prior to the passing of this Act.

(3) As regards a Board constituted under this Act, the meeting shall be held in the twelfth month after the appointment of the Board, and thereafter in the same month of every succeeding year.

84. (1) Ordinary meetings of the Board shall be held at such times, not being less than once in each quarter, as the Board determines.

Times for meetings.
Ibid., s. 83.

(2) Special meetings may be held at any time.

(3) The Chairman may call a special meeting at any time, and on the requisition, in writing, of three members of the Board, he shall call such a meeting.

(4) If the Chairman refuses, or for two clear days fails, to call a special meeting upon any such requisition, any three members may call a special meeting by public notice, signed by them, and stating the object of the meeting, and the time and place of holding the same.

85. Any

PART III.
DIVISION VI.

Vermin Act.—1931.

Adjournment.
Ibid., s. 84.

85. Any meeting may be adjourned to any time.

Ordinary business
may be done at
special meeting.
Ibid., s. 85.

86. Business required to be done at an annual or ordinary meeting may be done at a special meeting.

Fourteen days
notice of meetings.
Ibid., s. 86.

87. The Secretary shall, unless and until otherwise provided by by-law, send by post to every member of the Board written notice of every meeting, specifying the time and place of meeting, and, in the case of a special meeting, the business to be done thereat. Every such notice shall be sent as aforesaid at least fourteen days before the date fixed for the meeting.

Quorum.
Ibid., s. 87.

88. (1) At all meetings of the Board, except where otherwise provided by this Act, one-half or a majority of the members for the time being shall form a quorum.

(2) The Secretary, in the absence of all the members, or any member present alone, or the majority of members present at a meeting at which there is no quorum, may, at the expiration of half an hour from the time fixed for the meeting, adjourn the same.

(3) Any business which could have been transacted at any such meeting may be transacted at the adjourned meeting.

Who to preside, and
his right to vote.
Ibid., s. 88.

89. At any meeting of the Board the Chairman, or in his absence such member as the members present at the meeting elect for that purpose, shall preside, and shall have a deliberative vote, and, in case of equality of votes, a casting vote.

Business of Board
to be carried on
notwithstanding
vacancy.
Ibid., s. 89.

90. Notwithstanding a vacancy in the office of a member of a Board, the business of the Board shall be carried on by the member or members actually in office, who shall have all the powers of the Board.

Validity of proceed-
ings of Board
notwithstanding
defect of appoint-
ment, &c.
Ibid., s. 90.

91. All proceedings of the Board, or of a committee of the Board, or of any person acting as a member of the Board, shall, notwithstanding any defect in the election or appointment of the members of the Board, or of any such Committee, or any of them, or of any person acting as aforesaid, or that they or any of them, were or was incapable of being members or a member of the Board, be as valid as if the members or member, or the said person, had been duly elected or appointed, and were or was capable of being members or a member.

Provision in case of
inability of Secre-
tary, &c., to
perform duties.
Ibid., s. 91.

92. If, in consequence of death, absence, or any lawful impediment, it is impossible or inconvenient for the Secretary or a member or other person to perform any particular matter or thing which by this Act he is required to perform, the Chairman, or if, for the like reason, it is impossible or inconvenient for the Chairman, the Board, may perform the matter or thing, or appoint some member or other person to perform it.

93. If

*Vermin Act.—1931.*PART III.
DIVISION VI.

93. If the day for a meeting, or adjourned meeting, or for any business required by this Act or any by-law to be held or done, falls on a Sunday, Good Friday, Christmas Day, or public holiday, the meeting shall be held, or business done, on the first day after the day on which it was so required to be held or done.

Business falling on
Sunday or holiday.
Ibid., s. 92.

94. No resolution passed at a meeting of the Board shall be revoked or altered at a subsequent meeting, except subject to the following conditions :—

Revocation or
alteration of
resolutions.
Ibid., s. 93.

- I. Written notice of an intention to propose the revocation or alteration shall be given or posted to each of the members twenty-one days at least before the date fixed for the subsequent meeting :
- II. The resolution for the revocation or alteration shall be carried by a majority consisting of at least two-thirds of the members present at the subsequent meeting, if the number of members present at the subsequent meeting is not greater than the number present when the resolution was passed, or by a majority if the number of members present at the subsequent meeting is greater than the number present when the resolution was passed.

95. The Board may—

- (a) appoint occasional or standing committees :
- (b) fix the quorum of every such committee :
- (c) continue, alter, or discontinue any such committee.

Committees of
Board and quorum.
Ibid., s. 94.

96. The following provisions shall apply to every such committee :—

Meetings of Com-
mittees.
Ibid., s. 95.

- I. One of its members shall be appointed chairman of the committee :
- II. The chairman may, from time to time, be removed by resolution of the committee :
- III. The committee may meet from time to time, and may adjourn from place to place as the committee thinks proper :
- IV. No business shall be done at any meeting unless the quorum (if any) fixed by the Board, or, if no quorum is fixed, three members, are present at the meeting :
- V. If the chairman of the committee is not present at any meeting, one of the members present shall be appointed chairman of the meeting :
- VI. All questions shall be determined by a majority of the votes of the members present :
- VII. The chairman shall have a deliberative vote, and in case of equality of votes, a casting vote.

PART III.
DIVISION VI.

Vermin Act.—1931.

Minutes of meetings.
Ibid., s. 96.

97. The Board shall cause minute-books to be kept by the Secretary of all the meetings of the Board, and of every committee thereof, and of the proceedings thereat, and the following provisions shall apply to the minutes :—

- I. The names of the members who attend at every meeting shall be entered therein :
- II. The names of all members voting on any question for the decision of which a division is called for shall be entered therein :
- III. The minutes of every Board meeting, and of every meeting of a committee until a report is agreed upon, shall be submitted for confirmation at the next succeeding meeting, or if that is omitted, to some subsequent meeting, and, if found correct, shall be signed by the chairman of the meeting at which the same are confirmed :
- IV. If the chairman refuses or neglects to sign the minutes for seven days after any such meeting, the same may be signed by any two members present and entitled to vote at the meeting :
- V. The minutes of a committee meeting at which a report is agreed to shall, if found correct, be signed at the meeting, or some adjournment thereof, by the chairman thereof.

Inspection of
minute-books
Ibid., s. 97.

98. (1) The minute-books shall, at all reasonable times, be open to the inspection of—

- (a) a member of the Board :
- (b) a creditor of the Board :
- (c) a ratepayer of the District.

(2) Creditors and ratepayers shall pay One Shilling for every such inspection, and may take copies of a minute.

Minute-books and
certified extracts
therefrom evidence.
Ibid., s. 98.

99. Every minute purporting to be such a minute as is mentioned in section 97 and to be signed, as provided by that section, or a copy of or extract from any such minute purporting to be attested by the seal of the Board and to be signed by the Secretary, shall be received as evidence in all Courts, and before all Judges, bodies politic, and persons, without proof that the meeting to which the same refers was duly convened or held, or that the persons attending thereat were members of the Board or members of a committee thereof, or of the signature of the Chairman or any members, or of the fact of his having been such Chairman, or of their having been members entitled to sign the minutes, or of the affixing of the seal or of the signature of the Secretary ; and all such matters shall be presumed until the contrary is proved.

Vermin Act.—1931.

PART III.

DIVISION VII.—CONTRACTS AND WORKS.

DIVISION VII.

100. (1) Contracts for the purposes of this Act may be made, varied, or discharged by a Board in manner following:—

Modes in which Board may make, vary, and discharge contracts.

Ibid., s. 99.

- I. A contract which, if made between private persons, would be by law required to be in writing, and under seal, may be made, varied, or discharged in writing under the common seal of the Board:
- II. A contract which, if made between private persons, would be by law required to be in writing, signed by or on behalf of the parties to be charged therewith, may be made, varied, or discharged in writing under the common seal of the Board, or in writing signed by the members of the Board, or any person acting by the direction and on behalf of the Board:
- III. A contract which, if made by private persons, would be by law valid, although made by parol only, and not reduced into writing, may be made, varied, or discharged in either of the two ways aforesaid, or by parol, with or without writing, by any person acting by the direction and on behalf of the Board.

(2) All contracts made according to the provisions of this section shall be effectual in law and binding on the parties thereto.

101. The Board may compound with a person who has entered into a contract with the Board, or by or against whom an action or proceeding has been brought or threatened against or on behalf of the Board, for such sum of money or other consideration as the Board thinks proper.

Power of Board to compound claims.

Ibid., s. 100.

102. The Board may, subject to the approval of the Commissioner, contract, upon such terms as the Board thinks fit, with any other corporate or public body for or with respect to the doing and the control and management by either or both of the contracting parties of any matter or thing which the contracting parties are, or either of them is, by law empowered to do, control, or manage; and the Board may carry out any such contract according to the tenor thereof.

Power of Board to contract with other public bodies in certain cases.

Ibid., s. 101.

103. The Board may carry out all works and undertakings and do or cause to be done all acts and things necessary for the suppression of vermin by the erection of vermin fencing or dog-proof fencing.

Works and undertakings of Board.

Ibid., s. 102.

1869, 1928, s. 4.

104. (1) The Board may, by by-law, require owners and occupiers of land within the District to erect and maintain a vermin fence or a dog-proof fence around all artificial and permanent supplies of water (except running streams) upon land owned or occupied by them respectively, subject to the directions of an inspector appointed by the Board, who shall determine the position of every such fence.

Fencing of water supplies.

1181, 1914, s. 103.

1869, 1928, s. 4.

(2) Every

(2) Every such fence shall be provided with a proper gate or gates, to be approved of by the inspector.

(3) The said gate or gates shall, during such months of the year and during such hours as are fixed by the Board, be kept closed by the owner or occupier.

(4) An owner or occupier who fails to keep any such gate or gates closed as aforesaid shall be guilty of an offence against this Act, and shall be liable to a penalty not exceeding Ten Pounds.

Failure to fence
water supplies
1181, 1914, s. 104.

105. (1) If an owner or occupier fails to erect or maintain a fence, as required under section 104, the Board shall give written notice to the owner or occupier to erect or maintain the same within a time specified in the notice.

(2) An owner or occupier who fails to comply with any such notice shall be guilty of an offence against this Act and shall be liable to a penalty not exceeding Twenty Pounds.

Power of Board to
fence on default.
Ibid., s. 105.

106. If, after the expiration of the time specified in a notice under section 105, any direction therein contained has not been complied with by the owner or occupier named therein to the satisfaction of the inspector, the Board shall undertake and carry out the said direction at the expense of the said owner or occupier, and may recover the said expense from him in a summary way or by action in any Court of competent jurisdiction.

Powers of Board to
enter upon lands,
etc.
Ibid., s. 106.

107. The Board and its officers, servants, and agents—

(a) may enter upon any lands within the District :

(b) may cut timber thereon :

(c) shall clear the land on each side of any fencing erected or maintained by the Board for a space of at least twelve feet :

(d) shall do all other acts and things necessary for the purposes aforesaid,

without being liable to any owner or occupier upon any claim or demand whatsoever in respect thereof.

Power of Board to
purchase fence.
Ibid., s. 107.

108. (1) The Board may, subject to section 48, purchase any fence erected along the boundaries of its District, or which it is convenient to acquire for the purposes of this Act.

(2) The price to be paid for any such fence purchased by the Board, unless mutually agreed between the owner thereof and the Board, shall be fixed by the Commissioner.

Vesting of vermin
fence in Board.
Ibid., s. 108.
1955, 1930, s. 16.

109. (1) All fences erected, purchased, or acquired by a Board shall vest in the Board. No payment made pursuant to section 115 in respect of any such fence to the Board by any occupier of land shall vest any interest in the fence in such occupier. (2) All

Vermin Act.—1931.PART III.
DIVISION VII.

(2) All fences erected, purchased, or acquired by two or more Boards shall belong to and be apportioned by the Commissioner between those Boards proportionately to the amount contributed by them respectively in erecting, purchasing, or acquiring the fences.

(3) Any fence erected by a Board pursuant to section 149 of the Vermin Districts Act, 1894, or section 105 of the Vermin Act, 1905, or section 105 of the Vermin Act, 1914, or section 106 of this Act, shall cease to be vested in the Board from such time as the Board receives the cost of the said erection.

110. (1) Every vermin fence and every dog-proof fence erected by a Board shall be erected and maintained to the satisfaction of the Commissioner.

Fences subject to approval of Commissioner.

1181, 1914, s. 109.
1869, 1928, s. 4.

(2) Any person authorised in writing by the Commissioner may at any time inspect any vermin fence or dog-proof fence erected or in course of erection by a Board.

(3) The Commissioner may, by writing under his hand, require a Board to alter a vermin fence or dog-proof fence which has not been constructed in accordance with the requirements of this Act, or to repair a vermin fence or dog-proof fence which is out of repair, and the Board shall alter or repair the fence accordingly.

111. (1) Where two Districts have a common boundary, the Board of either District may require the Board of the other District to join in or contribute equally to the cost of the erection of wire netting or a vermin fence or dog-proof fence along the common boundary.

Contribution to erection of fence by other Boards.

1181, 1914, s. 110.
1869, 1928, s. 4.

(2) Every such requisition shall be by notice, which notice shall be sufficiently authenticated, without the common seal of the Board, if signed by the Chairman, or by the Secretary, and may be served by posting the same, addressed to the Chairman or the Secretary of the Board to which it is intended to be given.

(3) If within three months after the service of a requisition to fence under this section, the Board served therewith has not begun to erect its portion of the wire netting or fence, or is not proceeding with the erection with all reasonable speed, the Board serving the notice may—

- (a) erect the whole of the wire netting or fence; and
- (b) recover half the cost of the erection thereof from the other Board in any Court of competent jurisdiction.

112. (1) A Board erecting a vermin fence or dog-proof fence along the common boundary between its District and another District may clear all scrub for a width not exceeding twelve feet on each side along the length of the fence.

Clearing land along fence.

1181, 1914, s. 111.
1869, 1928, s. 4.

(2) The cost of the said clearing shall be deemed to be part of the cost of the fence.

113. The

PART III.
DIVISION VII.

Vermin Act.—1931.

Cost of maintaining
fences.

1181, 1914, s. 112.
1955, 1930, s. 17.

113. The cost of maintaining and keeping in repair a fence erected, purchased or acquired by or vested in a Board shall be borne by the Board; but where the fence is along the common boundary between two Districts, or along portion of any such boundary, the cost of the maintenance and repair of the fence shall be borne equally by the Boards of the two Districts.

Gates at junction
with another fence.

1181, 1914, s. 113.
1869, 1928, s. 4.

114. (1) The owner of a fence which joins, abuts on, or is connected with a vermin fence or a dog-proof fence erected by a Board shall provide, at or about the point at which the fence joins, abuts on, or is connected with the vermin fence or the dog-proof fence, a suitable gate, at least twelve feet wide, so as to allow free passage for the purpose of inspection and repair under section 110.

(2) On default by the owner the Board may provide and erect a gate and recover the cost thereof from the said owner.

(3) For the purposes of this section "owner" includes the occupier of the land on which the fence is erected.

Liability of adjoining
occupiers.

1181, 1914, s. 114.
1398, 1919, s. 5.
1703, 1925, s. 66.
1869, 1928, s. 4.

115. (1) The occupier of land which is not within but abuts on a District, and is enclosed with a vermin fence or a dog-proof fence, or is portion of an area enclosed within a vermin fence or a dog-proof fence, shall, three months after demand upon him, be liable to pay to the Board owning the fence dividing his land from the District one-half of the value of the fence at the time of the demand.

(2) The said occupier may pay the said amount in twenty equal yearly instalments, together with simple interest on the balance for the time being remaining unpaid. The said interest shall be at a rate equal to the fixed rate, except in a case where the Board has obtained a loan from the Bank for the erection and maintenance of the last-mentioned vermin fence or dog-proof fence, in which case the interest shall be at the rate paid by the Board in respect of the said loan.

(3) The first of the said instalments shall become due one year after the service of the demand upon the occupier, and one of the said instalments shall become due on the same date in every year thereafter until the whole amount has been paid.

(4) In this section the word "occupier" includes any person who is in the actual occupation of, or is entitled as owner to occupy, any land alienated from or demised by the Crown by grant, agreement, or lease, or who holds lands under licence from the Crown; but does not include any person in the occupation of or entitled to occupy land held under the Crown by yearly licence.

Payment of interest
by adjoining
occupiers.

1955, 1930, s. 18.

116. (1) If any occupier of land outside a District which land abuts on the vermin fence or dog-proof fence of a Board and which, but for the vermin fence or dog-proof fence would be without a boundary

Vermin Act.—1931.

PART III.
DIVISION VII.

boundary fence, avails himself of the vermin fence or dog-proof fence of the Board by keeping or depasturing sheep or cattle on the land abutting thereon, the said occupier shall, for so long as he continues to avail himself of the said fence as aforesaid, pay to the Board owning the fence—

(a) if the land is enclosed with a vermin fence or dog-proof fence, Five Pounds per centum per annum on one-half of the amount of the value of the fence at the time it is first availed of as aforesaid, or if the fence was so availed of on the sixteenth day of October, nineteen hundred and thirty, then on one-half of the amount of the value of the fence at the said day; but the value of any such vermin fence or dog-proof fence shall in no case be deemed to be less than Fifty Pounds per mile of such fence:

(b) if the land is not enclosed with a vermin fence or dog-proof fence, Five Pounds per centum per annum on one-half of the amount of the value of the fence estimated as if it were a sheep-proof fence or cattle-proof fence (according to whether sheep or cattle are depastured on the said land) in a similar state of repair as the vermin fence or dog-proof fence at the time it is first availed of as aforesaid, or if the fence was so availed of on the sixteenth day of October, nineteen hundred and thirty, then on one-half of the amount of the value estimated as aforesaid, of the fence at the said day; but the value of any such sheep-proof fence or cattle-proof fence shall in no case be deemed to be less than Thirty Pounds per mile of such fence.

(2) If any occupier of land inside a District which land abuts on the vermin fence or dog-proof fence of a Board, and which, but for the vermin fence or dog-proof fence would be without a boundary fence, avails himself of the vermin fence or dog-proof fence of the Board by keeping or depasturing sheep or cattle on the land abutting thereon, the said occupier shall, for so long as he continues to avail himself of the said fence as aforesaid, pay to the Board owning the fence Five Pounds per centum per annum on one-half of the amount of the value of the fence, estimated as if it were a sheep-proof fence or cattle-proof fence (according to whether sheep or cattle are depastured on the said land) in a similar state of repair as the vermin fence or dog-proof fence at the time it is first availed of as aforesaid, or if the fence was so availed of on the sixteenth day of October, nineteen hundred and thirty, then on one-half of the amount of the value estimated as aforesaid, of the fence at the said day; but the value of any such sheep-proof fence or cattle-proof fence shall in no case be deemed to be less than Thirty Pounds per mile of such fence.

(3) Any sum payable pursuant to this section shall be payable annually, and shall be devoted by the Board to which it is paid towards the maintenance of the fence in respect of which it is paid.

DIVISION

PART III.

Vermin Act.—1931.

DIVISION VIII.

DIVISION VIII.—REVENUE AND EXPENDITURE.

Revenue of a Board.
1181, 1914, s. 116.

117. The revenue of a Board shall be comprised as follows:—

I. Rates which the Board is by this Act authorised to declare:

II. Fines and penalties imposed or inflicted—

(a) for any offence against this Act, committed within the District; or

(b) for any offence committed by, or for any breach or neglect of duty on the part of, any member of the Board, or any ratepayer, officer, or other person in any matter relating to the District or Board, or to any member of the Board or officer, or in respect of any election or meeting or proceeding in connection with the District or Board, or any member of the Board or officer:

in which cases the said fines and penalties shall be paid to the Board for the use and benefit of the District, save any fine or portion thereof ordered, in pursuance of this or any other Act, to be paid to any other person:

III. All other moneys received by the Board, or by any officer thereof by virtue of this Act or otherwise, not being moneys which the officer is entitled to retain.

Banking and drawing of moneys.
Ibid., s. 117.

118. (1) All moneys received by any officer on account of the Board shall be credited to a fund to be called the Vermin Board Fund, and shall be paid into the bank appointed by the Board to receive the said moneys.

(2) Payment as aforesaid shall in every case be made as soon as the moneys in hand amount to Five Pounds or more.

(3) Every payment of One Pound or more to be made on behalf of the Board shall be made by a cheque on the Board's bank, drawn by the Chairman and one member of the Board authorised from time to time by the Board in that behalf, and countersigned by the Secretary.

(4) Payments of less than One Pound may be made out of a petty cash account, which shall be replenished from time to time by cheques drawn for that purpose.

Expenditure of revenue.
Ibid., s. 118.
1955, 1930, s. 19.

119. A Board may expend its moneys—

(a) in preparing for, carrying out, improving, and maintaining any works and undertakings authorised by this Act:

(b) in paying salaries and fees to any officers of the District, or persons in the employ of or appointed by the Board:

(c) in paying for the destruction of vermin on the whole or any specified portion of the land within the District, or on any land outside the District; Provided that the approval

*Vermin Act.—1931.*PART III
DIVISION VIII.

approval of the Commissioner to the payment is obtained and notice of the approval is published in the *Gazette* before payment is made :

- (d) in payment or part payment of the travelling expenses of members incurred in attending meetings of the Board, or when engaged on special business at the request or by the authority of the Board : Provided that the said request or authority is in writing :
- (e) in payment for professional and other like services necessary or desirable in and about the property and business of the Board :
- (f) generally in performing the duties and transacting the business of the Board as required or authorised by this Act.

120. No Board shall expend in any year for salaries and fees to officers, printing, advertising, stationery, and office expenses more than one-fourth of the whole of the rates declared for the District for that year.

Limit to expenditure for salaries, &c.
1181, 1914, s. 119.

121. (1) The Board shall keep proper accounts of all sums of money received and paid, and of the several purposes for which the said sums of money have been received and paid respectively.

Duty of Board to keep account of moneys received and paid.

(2) The said accounts shall be balanced twice at least in every period of twelve months ending on the thirtieth day of June.

Ibid., s. 120.

(3) Every ratepayer of the District may, at all reasonable times, upon payment of One Shilling to the Secretary, and every auditor for the District may, at all reasonable times without payment, inspect and take copies of or extracts from the said accounts, both before and after the same are audited, and of the abstract and statement of balance mentioned in section 122.

122. (1) Every Board shall, during the month of July in every year, cause an account, in abstract, to be prepared, with a statement of the balance of the said account.

Duty of Board to cause annual accounts to be made.

(2) The account shall show, under the several distinct heads of receipt and expenditure, the total receipt and expenditure of all funds received by virtue of this Act, for the period of twelve months ended on the preceding thirtieth day of June.

Ibid., s. 121.

(3) The account and statement shall be duly audited and certified by the auditors, and by the Chairman or two members of the Board, and by the Secretary.

DIVISION IX.—MAKING AND RECOVERING RATES.

DIVISION IX.

123. The first rate declared by a Board shall be for the portion of the year between the date of the publication of the proclamation constituting the District and the thirtieth day of June next after the declaring of the rate.

Rate for portion of year after constitution of District.

Ibid., s. 122.

PART III.
DIVISION IX.

Vermin Act.—1931.

Duty of Board
before making rate
to make estimate
and keep it in book
for inspection.

Ibid., s. 123.

124. (1) The Board, before proceeding to declare a rate, shall prepare an estimate of the sum required for the several purposes in respect of which it is authorised to expend or apply its revenue.

(2) The estimate shall show—

- (a) the several sums (if any) already available for the said purposes ;
- (b) the several sums required ;
- (c) the number of square miles of ratable property within the District ; and
- (d) the rate or rates per square mile which will be necessary to raise the sum required.

(3) The said estimate, when approved by the Board, shall be entered in a book, to be called the Estimate Book.

(4) The said book shall be kept at the Vermin Board Office, and shall be accessible to the ratepayers at all reasonable hours.

General rate.

Ibid., s. 124.

1528, 1922, s. 4.

1749, 1926, s. 2.

1869, 1928, s. 4.

125. (1) After making the said estimate the Board shall, for the general purposes of this Act, declare a rate on the ratable property within the District for the period of twelve months ending on the thirtieth day of June next after the declaring of the rate.

(2) The said rate shall not exceed Ten Shillings on each full quarter of a square mile of the ratable property within the District: The Board may, whenever it appears equitable, declare a smaller rate or smaller rates in respect to any ratable property to be specified by the Board which adjoins or is in proximity to any existing or intended or proposed vermin fence or dog-proof fence by reason that the said ratable property is not or will not be benefited by the fence to the same extent as the other ratable property within the District.

(3) Land enclosed with a vermin fence or with a dog-proof fence, which, in the opinion of the Board, is erected and maintained in an effective manner, shall be exempt from the rate: Provided that any such exemption shall not apply where the whole or any portion of the said fence has been purchased by the Board, and shall not apply to any land enclosed with a vermin fence or a dog-proof fence after the fifth day of December, nineteen hundred, if the fence has been erected after the constitution of the District in which the land is situated.

(4) No owner holding less than a quarter of a square mile of land in the District shall be liable to pay any rate under this section.

(5) The exemptions from rates provided by subsections (3) and (4) of this section shall not apply in respect of any land which is, for the time being, subject to any charge under Division I. or Division II. of Part V. of this Act, or under Division I. of Part VI. of the Vermin Act, 1905, whether under that Division as passed or under that Division read as provided by section 5 of the Vermin Act Amendment Act, 1911, or under Division I. or Division II. of Part VI. of the Vermin Act, 1914.

*Vermin Act.—1931.*PART III.
DIVISION IX.

126. The following provisions as regards rates shall apply in a District which is not situated within the limits of a District Council District :—

- I. The Board shall, as soon as possible after the declaration of a rate, inform the Commissioner thereof :
- II. The Commissioner shall forthwith publish in the *Gazette* a notice containing the names of the ratepayers liable to pay the said rate, the amount thereof, and the date for payment thereof :
- III. The said rates shall be paid to the Commissioner, and may be levied and recovered by or under the authority of the Commissioner in like manner as any rent is recoverable under any lease, or in a summary way :
- IV. Where any such rate is levied by distress, a warrant under the hand of the Commissioner shall be a sufficient authority to distrain :
- V. The Commissioner shall, on receipt of the proceeds of any rate or rates as aforesaid, pay the same to the credit of the Board in the Bank appointed by the Board :
- VI. The Board shall pay to the Commissioner all costs and expenses incurred in receiving, collecting, recovering, and distributing rates :
- VII. The Commissioner may deduct the said costs and expenses from the proceeds of any rates passing through his hands, or may recover the same by action in any Court of competent jurisdiction.

Duty of Commissioner to publish notice specifying rate, persons liable to pay the same, and the date for payment.

1181, 1914, s. 126.

127. The following provisions as regards rates shall apply in a District which is situated within the limits of a District Council District :—

- I. The Board shall forthwith after the declaration of a rate publish in the *Gazette* a notice containing the names of the ratepayers liable to pay the said rate, the amount thereof, and the date for payment thereof :
- II. Rates shall be paid to the Board, and may be levied and recovered by or under the authority of the Board in like manner as rent under a lease is recoverable, or in a summary way :
- III. Where any such rate is levied by distress, a warrant under the hand of the Chairman and the seal of the Board shall be sufficient authority to distrain.

Rates where District within District Council.

Ibid., s. 126.

128. (1) Notwithstanding anything contained in sections 126 and 127, the Commissioner may, upon the request in writing of the Board of any District which is situated within the limits of a District Council District, undertake the collection of rates for the District of the Board.

Power of Commissioner upon request to collect rates where District within District Council District.

1398, 1919, s. 6.

PART III.
DIVISION IX.

Vermin Act.—1931.

(2) For the purposes of the collection of rates under this section, the Commissioner shall have all the powers and be subject to all the duties, with respect to the recovery of the said rates, which are conferred and imposed upon him by section 126.

Penalty for non-payment of rates on the day appointed.

1181, 1914, s. 127.

129 (1) A penalty of Five Pounds per centum shall be added to the amount of a rate payable under the authority of this Act which is not paid on or before the day appointed for payment thereof.

(2) A further penalty of Five Pounds per centum shall be added if the rate and first penalty are not paid within three months after the said day.

(3) The said rate and penalties may be recovered at any time after they become due by the Commissioner, or by the Board (as the case may be), by action in his or its name in any Court of competent jurisdiction.

DIVISION X.

DIVISION X.—LOANS.

Loans from State Bank.

1181, 1914, s. 128.

1703, 1925, s. 66.

1749, 1926, s. 3.

130. (1) The Board may borrow money from the Bank for the purpose of defraying the cost of the erection and maintenance of the fence or fences decided upon by the Board if the proceeds of one year's rate are insufficient for the purpose.

(2) The Board shall repay the sum so borrowed in twenty equal annual instalments, together with simple interest on the balance for the time being unpaid at the fixed rate. Any sum so borrowed after the second day of December, nineteen hundred and twenty-six, shall bear interest at the fixed rate, and the principal, together with the interest thereon, shall be repaid in twenty equal yearly instalments, to be calculated at a rate sufficient to repay the said principal together with interest on the balance thereof from time to time remaining unpaid.

(3) Payment of each of such annual instalments is hereby made a first charge upon the annual rates of the District.

Time for repayment of loans may be extended.

1398, 1919, s. 7.

1703, 1925, s. 66.

1749, 1926, s. 4.

131. (1) The Bank may, upon the application in writing of a Board, and if the Bank is of opinion that it is necessary in order to avoid great hardship, extend the time for the repayment of any loan made to the Board for any period not exceeding thirty years from the date whereon the loan was originally made.

(2) Upon any such extension, the balance of the loan remaining unpaid at the time when the extension was made shall be repaid by equal annual instalments spread over the remainder of the term of the loan as extended, together with simple interest on the balance for the time being unpaid at the fixed rate. If the loan was originally made on a date after the second day of December, nineteen hundred and twenty-six, then, upon any such extension, the balance of the loan and interest thereon remaining unpaid at the time when the extension was made shall be repaid, together with interest at the fixed rate on the balance of the loan for the time being unpaid, by such equal annual instalments spread over the remainder of the term of the loan as extended as are fixed by the Bank.

132. A

*Vermin Act.—1931.*PART III.
DIVISION X.

132. A loan under section 130 may be made out of moneys voted by Parliament for the purpose of making such loans.

Appropriation of funds.
1181, 1914, s. 129.

133. (1) The Board before applying for a loan shall prepare—

- (a) plans and specifications of the work in respect of which the loan is to be expended ;
- (b) an estimate of the cost of the work ; and
- (c) a statement showing the proposed expenditure of the loan.

Duty of Board before borrowing to prepare plans, estimates, &c.
Ibid., s. 130.

(2) The said statement shall be open to the inspection of the ratepayers.

134. Upon default being made by the Board in the repayment of a loan or any instalment of a loan—

Powers of Bank on default of payment.
1703, 1925, s. 66.

- (a) the Bank shall have all the rights of a creditor of the Board in respect of any sum of money due in respect of the loan or instalment, and may charge interest thereon at a rate being One Pound per centum per annum in excess of the fixed rate :
- (b) the Commissioner may from time to time pay to the Bank the proceeds of any rate or rates received by him or passing through his hands, pursuant to this Act, towards the payment of such loan or instalment and interest until the same are fully paid.

135. The Board may at any time pay off the whole or any part of a loan.

Power to pay off.
1181, 1914, s. 132.

136. No transfer or absolute surrender of the lease of any land within a District shall be allowed until the Board of the District, has repaid all loans made to it by the Government or the Bank under this Act, or under any repealed Act, unless the Commissioner—

Loans to be repaid before transfer or surrender.
Ibid., s. 133.
1703, 1925, s. 66.

- (a) is satisfied that the proportion of any such moneys owing by the Board payable in respect to the lease proposed to be transferred or surrendered will be duly paid as and when the same becomes payable ; and
- (b) consents to the transfer or surrender.

DIVISION XI.—OFFICERS OF A DISTRICT.

DIVISION XI.

137. The Board may—

- (a) appoint, in addition to the Secretary, a treasurer, a surveyor, an overseer of works, inspectors, and rangers, and such other officers as are necessary :
- (b) pay such salaries and allowances to the said officers out of the District Fund as the Board determines.

Appointment and salaries of officers.
1181, 1914, s. 134.

138. The

PART III.
DIVISION XI.

Vermin Act.—1931.

Security for fidelity
of officers entrusted
with moneys.

Ibid., s. 135.

138. The Board may, before any officer entrusted by the Board with the custody or control of any moneys by virtue of his office, enters upon his office, take sufficient security by guaranty from some person or company, or by deposit, for the fidelity of that officer.

Officers to deliver
accounts and
vouchers and hand
over balances.

Ibid., s. 136.

139. (1) Every officer appointed or employed by the Board shall, when required by the Board, make out and deliver to the Board, or to any person appointed by the Board for that purpose, a true and perfect account, in writing, under the hand of the officer, of all moneys received and of all moneys paid by him on behalf of the Board.

(2) The said accounts shall show from whom and on what account, any such moneys have been received, and to whom and on what account any such moneys have been paid.

(3) The said officer shall deliver up with the said account all vouchers and receipts for the said payments.

(4) The said officer shall pay to the Board, or to any person appointed by the Board to receive the same, all moneys which appear to be owing to the Board by that officer upon the balance of the account.

Officers failing to
deliver accounts or
to pay balance or
deliver over property
of Board.

Ibid., s. 137.

140. (1) If any such officer fails—

(a) to deliver such account as aforesaid ; or

(b) to produce and deliver up the vouchers and receipts relating to the same in his possession or power ; or

(c) to pay any moneys in his hands payable to the Board when thereunto required ; or

(d) to deliver up to the Board, or to any person appointed by the Board to receive the same within seven days after being thereunto required, all papers and writings, property, matters, and things in the possession or power of the officer relating to the execution of this Act, or belonging to the Board,

a Court of Summary Jurisdiction may hear and determine the matter in a summary way, and may order the officer to deliver such account or to deliver up such vouchers and receipts as aforesaid, or to pay over the moneys owing by him, and to deliver up all such papers, writings, property, matters, and things as aforesaid.

(2) If any such officer neglects to obey any such order, he may be committed to gaol by any Justice for any period not exceeding six months.

Proceedings against
officer or past officer,
and remedy against
surety.

Ibid., s. 138.

141. (1) All proceedings against any officer under section 140 may be had and taken and enforced against him after he has ceased to hold his office.

(2) No

*Vermin Act.—1931.*PART III.
DIVISION XI.

(2) No such proceeding against any officer or past officer shall deprive the Board of any remedy which the Board may have against any surety of the officer or past officer.

DIVISION XII.—BY-LAWS AND REGULATIONS.

DIVISION XII.

142. The Board may make by-laws for carrying out the provisions of this Part, and for the following purposes:—

Purposes for which by-laws may be made.

Ibid., s. 139.

- I. To regulate the manner of calling and holding meetings of the Board and committees thereof, and the quorum of any such committees :
- II. To regulate the form of public notices to be published by the Board, and the places of posting the same :
- III. To regulate elections and the appointment of officers or other persons to carry out the provisions of this Part in relation to elections :
- IV. To regulate the appointment, duties, and control of all or any officers or servants of the Board, and the time and mode of payment of their salaries and fees :
- v. To fix or regulate the securities to be taken from or on behalf of, or to secure the fidelity of, any officer or servant :
- VI. To regulate the making or declaring of rates :
- VII. For the appropriation and expenditure of the revenue of the Board :
- VIII. For the punishment of persons falsely representing themselves to be officers of or appointed by the Board :
- IX. For the more effectual exercise of the powers, and discharge of the duties and liabilities, hereby conferred and imposed on the Board :
- x. To require owners and occupiers to fence supplies of water, pursuant to section 104 :
- XI. To fix pecuniary penalties for offences against or breaches of the by-laws or any of them, and to fix additional penalties for a repetition or continuance of any offence :
Provided that the penalty so fixed for any single offence shall not exceed Ten Pounds.

143. (1) At least two-thirds of the members of the Board in office at the time shall be present at the meeting of the Board at which any by-law is passed.

Passing of by-laws.
Ibid., s. 140.

(2) No by-law shall be of any force until signed by the Chairman and Secretary and confirmed by the Governor, and published in the *Gazette*.

(3) After

PART III.
DIVISION XII.

Vermin Act.—1931.

(3) After the expiration of one month from the publication as aforesaid of any by-law, the by-law shall have the force of law, and shall, until altered or repealed, have the same effect within the District as if the by-law were part of this Act.

No by-law to be repugnant to any laws.

Ibid., s. 141.

144. No by-law shall be repugnant to this or any other Act, or to any regulations made by the Governor under this or any other Act.

Board not to inflict penalty except by by-law.

Ibid., s. 142.

145. No Board shall be authorised to inflict any punishment except by way of penalty as provided by section 142.

Alteration of by-laws.

Ibid., s. 143.

146. Any by-law made by the Board may be altered or repealed—

(a) by a subsequent by-law of the Board inconsistent therewith or expressly altering or repealing the same :

(b) by regulations inconsistent with the by-law made by the Governor under any Act :

(c) by a proclamation by the Governor, published in the *Gazette*, expressly altering or repealing the by-law.

Saving of past operation of repealed or altered by-law.

Ibid., s. 144.

147. Notwithstanding the repeal or alteration of any by-law, every offence committed against the by-law before the repeal or alteration thereof shall be adjudicated upon, and every act or proceeding done or commenced, and every right, privilege, or protection acquired, and every liability incurred, shall continue, be prosecuted, and be of the same force and effect as if the by-law had not been altered or repealed.

Numbering, &c., of by-laws.

Ibid., s. 145.

148. All by-laws shall be intituled as of the District of which they are by-laws, and according to the purport thereof, and according to the Part or section of this Act under which they are made, and shall be numbered consecutively, and so that no by-law shall bear the number borne by any other by-law of the District.

Exemptions from double prosecution.

Ibid., s. 146.

149. No person shall be prosecuted or punished for the same offence under this Act, or any by-law continued hereby or made hereunder, and also under any other Act or any by-law or regulation made thereunder.

Facilities for testing the validity of by-laws.

Ibid., s. 147.

150. (1) Any ratepayer of a District who desires to dispute the validity of any by-law made, or purporting to be made, under this Act, may apply to the Supreme Court, upon an affidavit setting out the facts, for a rule calling upon the Board concerned to show cause why the by-law should not be quashed for illegality.

(2) No such rule shall be drawn up until the ratepayer has given security to the satisfaction of the Master of the Supreme Court for the sum of Fifteen Pounds for the costs of the proceedings.

(3) The Court may make the said rule absolute or discharge it, with or without costs as to the Court seems fit.

151. (1) The

*Vermin Act.—1931.*PART III.
DIVISION XII.

151. (1) The Governor may make regulations for the carrying out of this Part, and in particular, and without derogating from his general power, he may make regulations—

Power of Governor to make regulations. Ibid., s. 148.

(a) prescribing the mode in which the account books and any other books of Boards shall be kept :

(b) requiring Boards to collect, for a remuneration to be fixed by the Governor in the case of each Board, agricultural, pastoral, and livestock statistics relating to their respective Districts, and to forward returns of the same to the Government Statist, or to the Chief Secretary.

(2) The Governor may annul, amend, and add to any such regulations as aforesaid, or make others in lieu thereof.

(3) All such regulations shall be published in the *Gazette*, and shall thenceforth, subject to subsection (5) hereof, have the force of law.

(4) All such regulations shall be laid before both Houses of Parliament within fourteen days after the making thereof, if Parliament is then sitting, and if not, then within fourteen days after the next Session of Parliament begins.

(5) If during that Session either House of Parliament passes a resolution objecting to any such regulations, the same shall (so far as so objected to) thenceforth cease to have the force of law, and notice of such resolution shall forthwith be published by the Commissioner in the *Gazette*.

152. If in any regulations made by the Governor by virtue of this Part there are any models of by-laws, a Board may, by a majority of the members present at any meeting at which there is a quorum, adopt any such models and make them by-laws of the District.

Power of Board to adopt without special majority any model by-laws given in regulations. Ibid., s. 149.

DIVISION XIII.—DIFFERENCES BETWEEN BOARDS.

DIVISION XIII.

153. (1) The following provisions shall apply to any difference, whether arising out of the construction of this Part or not, which arises between any two or more Boards touching and relating to the carrying out of the provisions of this Part, or touching or relating to the fulfilment and exercise of the duties, powers, privileges, or authorities of any such Boards :—

Reference of differences between Boards to Commissioner. Ibid. s. 150. 2017, 1931, s. 3.

i. The said difference shall be referred to the Commissioner, who is hereby authorised and empowered—

(a) to entertain, inquire into, and decide upon the same ;

(b) to hear, receive, and examine evidence upon oath, which oath he is hereby empowered to administer ;

(c) to

- (c) to summon, if he thinks fit, two or more assessors ;
- (d) to compel the attendance of witnesses, call for the production and examination of documents, and commit for contempt ; and
- (e) to do all such other matters and things relating to the difference in the same manner and to the like extent as the same may be done by any Judge of the Supreme Court in the exercise of his jurisdiction :

II. The decision of the Commissioner with regard to any such difference shall be final, and may be made a rule of the Supreme Court.

(2) The Commissioner may in respect of any such difference as aforesaid by notice in writing delegate to any person all or any of the authorities or powers conferred upon the Commissioner by this section (including the power to make a decision as aforesaid), and such person shall thereupon have and may exercise such delegated authorities and powers.

PART IV.

PART IV.

VERMIN FENCING AND DOG-PROOF FENCING BY THE CROWN.

Power of Commissioner to erect vermin and dog-proof fences.
1181, 1914, s. 156.
1249, 1916, s. 4.
1869, 1928, s. 4.
1990, 1930, s. 4.

154. (1) The Commissioner may erect vermin fences and dog-proof fences which shall be paid for out of moneys appropriated by Parliament for the purpose : Provided that—

(i) a plan showing—

- (a) the proposed situation and description and the estimated cost of any fence proposed to be so erected, and the estimated amount of all contributions (if any) in respect of existing vermin fences or dog-proof fences which it is contemplated will be payable by the owners and occupiers hereinafter referred to ;
- (b) the land which will be benefited by the erection of the fence ;
- (c) the names of the owners or occupiers of the said land ;
- (d) the proportion of the cost of the fence and of the contributions (if any) which it is estimated will be payable by every such owner or occupier ; and
- (e) the rate which it is estimated will be payable by every such owner or occupier in respect of his land,

shall be laid before Parliament for a period of thirty days, and a copy of the said plan shall be forwarded to every owner or occupier therein named ; and

(ii.) no

Vermin Act.—1931.

PART IV.

(ii.) no such fence shall be erected unless, after the expiration of the said period of thirty days, a resolution is adopted by each House of Parliament, approving the erection thereof.

(2) The cost of any fence erected under this section, together with the cost of the maintenance and supervision thereof, shall be borne by the owners or occupiers for the time being of the lands which are indicated on the plan under subsection (1) hereof as lands which will be benefited thereby.

(3) Every such owner or occupier shall pay his proportion of the cost of the fence in twenty equal yearly instalments, together with simple interest on the balance for the time being unpaid at the fixed rate, and his proportion of the cost of the maintenance and supervision of the fence. The amounts so payable may be paid by means of the rates imposed under subsection (4) hereof.

(4) The Commissioner shall, from time to time, calculate the amounts to be paid by any owner or occupier under subsection (3) hereof, and shall every year impose a rate upon the land of that owner or occupier sufficient to produce the amount to be paid by him for the year. The rate so calculated shall be due by the owner or occupier in respect of his land, or by the owner or occupier for the time being of the land, and shall be recoverable accordingly by the Commissioner or any person authorised by him in that behalf by action in any Court of competent jurisdiction or summarily.

(5) Any rate payable under subsection (4) hereof which is unpaid for fourteen days next after the date whereon the same becomes payable shall, by way of penalty, bear interest which shall be payable therewith, calculated at a rate being One Pound per centum per annum in excess of the rate of interest payable under subsection (3) hereof.

(6) Notwithstanding anything herein contained, any owner or occupier may at any time repay all instalments with interest thereon then remaining unpaid; but no such repayment shall relieve any owner or occupier of his liability to pay his proportion of the cost of maintenance and supervision of the fence.

(7) In any case where lands are not, by reason only of the erection of a fence pursuant to this section, a vermin-fenced area, but, by reason of the said fence and previously existing vermin fences or dog-proof fences, whether fences of any Vermin-Fenced District or Districts or fences the property, in whole or in part, of any owners or occupiers (each of whom is hereinafter called a "private owner"), the said lands are a vermin-fenced area, then the owners or occupiers referred to in subsection (2) hereof shall, in addition to bearing the cost referred to in that subsection, pay to the Board of every such District, and to every such private owner, one-half of the value, at the time of the erection of the fence pursuant to this section, of such portion of the vermin fence or dog-proof fence of such District, or of such
private

PART IV.

Vermin Act.—1931.

private owner's interest in such portion of a vermin fence or a dog-proof fence (as the case may be) as forms portion of the boundary of the vermin-fenced area, together, in the case of any amount so to be paid to a Board, with interest thereon at the rate referred to in section 48.

(8) The capital amounts to be paid pursuant to subsection (7) hereof, and the proportions thereof to be paid by the owners and occupiers respectively, shall be fixed by the Commissioner by an order or orders, which shall be published in the *Gazette*; and, in fixing the amount which any such owner or occupier is to pay to the private owner of any such vermin fence or dog-proof fence as aforesaid, the Commissioner shall deduct any contribution which the owner or occupier has made towards the value of the fence.

(9) The capital amount and interest so to be paid by any owner or occupier to a Board shall be paid in the manner and at the times mentioned in subsection (1) of section 48: Provided that any owner or occupier may at any time pay all instalments thereof, with interest thereon, then remaining unpaid.

(10) The amount so to be paid by any owner or occupier to a private owner shall be due and payable at the expiration of one month from the publication in the *Gazette* of the order fixing the amount.

(11) Any sum payable under this section shall be recoverable by action in any Court of competent jurisdiction, or summarily.

(12) For the purposes of this section, the Director of Lands shall be deemed to be the occupier of Crown lands.

Power of Governor
to constitute the
fenced area a
Vermin-Fenced
District.
1181, 1914, s. 157.

155. (1) In every case where a fence is erected under section 154 of this Act, section 156 of the Vermin Act, 1914, or section 159 of the Vermin Act, 1905, the Governor, on the recommendation of the Commissioner, may by proclamation declare the lands shown on the plan (with respect to the said fence) under subsection (1) of the said section 154 or of the said section 156 or of the said section 159 (as the case may be), as the lands which would be benefited by the said fence, to be a Vermin-Fenced District for the purpose of this Act.

(2) The power conferred by subsection (1) hereof may be exercised without any petition and notwithstanding that the provisions of section 45 have not been observed in the particular case: Provided that—

(a) the proclamation shall assign a name to the District thereby constituted and shall define the boundaries thereof; and

(b) subsection (4) of the said section 45 shall apply.

(3) Upon and from the constitution under subsection (1) hereof of a Vermin-Fenced District, all the provisions of this Act shall apply as if the District had been constituted under section 45: Provided that the provisions of subsections (2) to (12) inclusive of section

Vermin Act.—1931.

PART IV.

section 154 shall continue to apply, instead of the provisions of this Act (as to matters dealt with in those subsections) which would apply in case the District had been constituted under section 45.

156. A document purporting to be certified by the Surveyor-General as a correct copy of a plan laid before Parliament under section 154 of this Act, under section 156 of the Vermin Act, 1914, or under section 159 of the Vermin Act, 1905 (as the case may be), shall be *prima facie* evidence that the owners and occupiers of the land shown on that document as the lands which would be benefited by the fence proposed to be erected, are liable under section 154 of this Act in respect of the cost of the fence erected under that section, and that they are so liable in the proportions shown on the said document.

Certified copy of plan to be *prima facie* evidence.
Ibid., s. 158.

157. The Commissioner, by himself or any person or body authorised by him in that behalf—

Power of Commissioner to erect vermin-proof fences across roads.
Ibid., s. 159.
1869, 1928, s. 4.

- (a) may erect a rabbit-proof, dog-proof, or other vermin-proof fence or gate across any road in the State not within any Municipality or District Council District :
- (b) shall provide and fix a gate of a width of at least twelve feet in every such fence :
- (c) may remove any such fence :
- (d) may order the removal of any fence or gate erected across any road, if, in his opinion, the removal is necessary for the public convenience :
- (e) shall at least six months before the said removal, give notice of the removal, by notice published in the *Gazette*, to occupiers affected by the fence, to enable them to erect the necessary fencing for the protection of their land.

PART V.

PART V.

WIRE NETTING AND VERMIN AND DOG-PROOF FENCING BY OWNERS AND OCCUPIERS.

DIVISION I.—GENERAL PROVISIONS.

DIVISION I.

158. In this Part—

“ Occupier ” includes the owner or tenant of any freehold land, and any person holding land from the Crown under a pastoral

Interpretation.
1181, 1914, s. 160.
1703, 1925, s. 66.

PART V.
DIVISION I.*Vermin Act.—1931.*

pastoral lease or agreement to purchase, or as scrub lessee, forest lessee, or miscellaneous lessee, or holding land from the Crown on lease with a right of purchase or on perpetual lease, or holding a perpetual lease of lands granted or dedicated by way of endowment for education :

“Special area” means the land for the benefit of which a loan is desired or intended to be applied for or which is described by an order of the Bank granting a loan.

Regulations.
1181, 1914, s. 161.

159. The Governor may make regulations prescribing the kind of wire netting fences to be erected in pursuance of this Part, and generally for carrying the purposes of this Part into effect.

DIVISION II.

DIVISION II.—WIRE NETTING BY MEANS OF LOANS TO
DISTRICT COUNCILS.

Power of Bank to
make loans for
wire netting fencing.
Ibid., s. 163.
1703, 1925, s. 66.

160. (1) A Council may borrow money from the Bank for the purpose of purchasing wire netting and supplying the same to occupiers of land in a special area within the District of the Council.

(2) The Bank may, on the application of a Council, grant a loan to the Council for the said purpose.

(3) All such loans shall be made out of any moneys voted by Parliament for the purposes of this section.

Application to be
preceded by a
petition.
1181, 1914, s. 164.

161. No Council shall apply for a loan until after the receipt by the Council of a petition under section 162.

Requisites of
petitions.
Ibid., s. 165.
1631, 1924, s. 2.
1703, 1925, s. 66.

162. Every petition to a Council to obtain a loan under section 160 shall—

- (a) describe the special area for which the petitioners desire a loan to be obtained by the Council, and state the acreage of the whole of the special area and the acreage held by each occupier of land therein :
- (b) be signed by a majority in number of the occupiers of the land in the special area :
- (c) be signed by petitioners occupying more than one-half of the land of the special area :
- (d) describe shortly the land occupied by each petitioner, and state the acreage thereof :
- (e) give an estimate of the probable cost of the whole of the wire netting required for the land in the special area, and ask that the Council will apply to the Bank for a loan of the amount of the estimate :

(f) give

*Vermin Act.—1931.*PART V.
DIVISION II.

- (f) give an estimate of the wire netting required for each petitioner's land and the probable cost thereof, and an estimate of the extent of fencing to be erected by each occupier :
- (g) state whether in the special area any two or more adjoining properties can advantageously be enclosed by one continuous wire netting fence instead of being separated by dividing fences, and, if so, state in each case the estimated cost of the continuous fence, and the proportion thereof to be borne by each occupier of property to be enclosed by the fence :
- (h) state that each petitioner signing the petition undertakes to pay to the Council in each year one-twentieth part of his proportion of the value of all wire netting obtained by the Council by means of the loan proposed to be obtained, together with interest at the fixed rate on the balance for the time being remaining unpaid, and also undertakes to pay annually to the Council, for the purpose of defraying the expenses of administration in connection with the loan, an additional sum calculated at the rate of Ten Shillings per centum per annum upon the amount, including interest, for the time being due by him in respect of his proportion of the value of the said wire netting, or if any such sum so calculated amounts to less than Two Shillings, then the sum of Two Shillings :
- (i) contain an undertaking by each petitioner to erect on his land, to the satisfaction of the Council, all the wire netting furnished to him, or to join with other occupiers in erecting all necessary fencing :
- (j) where a petition is signed by one occupier only, the requirements of this Act shall be complied with as nearly as possible by that occupier ; and the signature of the petitioner, instead of being verified as provided in section 163, shall be verified by a Justice.

163. Every signature to a petition shall be verified by the solemn declaration of some person signing the petition, and the declaration shall be in the form in the Ninth Schedule, or in a form to the like effect.

Signatures to
petition.
1181, 1914, s. 166.

164. No petition shall be received by a Council unless accompanied by a declaration as required by section 163.

Declaration to
accompany petition.
Ibid., s. 167.

165. Every petition shall be left with the Clerk of the Council and shall thereupon be deemed to be duly presented.

Presentation of
petition to
Council.
Ibid., s. 168.

166. (1) The Council shall consider any petition so presented, and shall, if the Council determines to apply for a loan in accordance therewith, transmit the petition to the Bank, together with any information the Council desires to convey, or which the Bank may require, in reference thereto.

Duty of Council to
transmit petition to
the Bank.
Ibid., s. 169.
1703, 1925, s. 60.

(2) The

PART V.
DIVISION II.

Vermin Act.—1931.

(2) The Council shall transmit, with the petition, an application for a loan on the terms prayed in the petition, or on such other terms as the Council thinks fit.

(3) The application shall contain an undertaking to repay the loan in accordance with the provisions of this Act.

(4) The application may be in the form in the Tenth Schedule.

Power of Bank to
grant loan.
1181, 1914, s. 170.
1703, 1925, s. 66.

167. (1) The Bank may, subject to such terms and conditions as the Bank thinks fit, make an order granting the whole or any part of the loan applied for.

(2) If part only of the loan is granted, the order shall state whether the loan is for the benefit of the whole of the land described in the petition or of any specified part of the said land.

(3) The Bank may, in the order, direct that any specified part or parts of the land described in the petition shall be enclosed by continuous wire netting, and that no part of the loan shall be expended in materials for the purpose of erecting or rendering vermin proof or rabbit proof any dividing fence within the said specified part or parts.

(4) Every loan shall be payable to the Council in the instalments specified in the order or determined by regulations.

(5) The proportion of the loan which each occupier of land in the special area shall pay to the Council shall be set out in the order.

(6) Every order made under this section shall be published in the *Gazette*, and shall be conclusive evidence of the statements contained therein.

Land in the special
area charged with
payment for
netting.
1181, 1914, s. 171

168. (1) All land of an occupier in a special area, whether the occupier thereof has signed the petition or not, shall (unless certified by the Council when forwarding the petition to be already sufficiently fenced with wire netting) be chargeable with payment for all materials for wire netting which the Council furnishes to the occupier of the said land, or offers to furnish to the said occupier, and whether the same is accepted by him or not, and also with the payment of the interest and additional sums mentioned in paragraph (h) of section 162.

(2) The undertaking referred to in paragraph (h) of section 162 shall, as between each person who signed the petition under that section, or the occupier for the time being of the land of the said person and the Council, be deemed to be, and may be enforced as, a specialty contract.

Powers of Bank if
Council unreason-
ably fails to apply
for loan.
Ibid., s. 172.
1703, 1925, s. 66.

169. (1) If a Council, having received a petition under section 162, does not apply under section 166 for a loan, the Council shall transmit the petition to the Bank together with any information the Council desires to convey, or which the Bank may require in reference thereto, and also with a statement of the reasons why the loan is not applied for.

(2) If

*Vermin Act.—1931.*PART V.
DIVISION II.

(2) If upon considering the petition, information, and statement the Bank is not satisfied that sufficient reasons exist for not applying for the loan, the Bank may give notice to the Council that the Bank proposes to make advances to the petitioners on account of the Council unless, within a time specified by the notice, the Council applies for the loan.

(3) If the Council does not within the time so specified apply for the loan the Bank may, subject to such terms and conditions as the Bank thinks fit, make an order granting advances to the petitioners, or any of them, of the whole or any part of the amount of the estimate given in the petition, and advances shall be made accordingly.

(4) The said advances shall be deemed to be made by the Bank on account of the Council, and all the provisions of this Act shall apply, *mutatis mutandis*, as if—

- (a) the order granting the advances were an order under section 167 granting a loan applied for by the Council ;
- (b) the total amount of the advances were a loan applied for and obtained by the Council, and were the value of wire netting obtained by the Council by means of the loan ; and
- (c) the amounts of the several advances were respectively the values of wire netting furnished by the Council under section 171 to the persons to whom advances are made by the Bank.

170. A Council receiving a loan shall keep a separate account-book in respect thereof, and full particulars shall be recorded therein of—

Keeping particulars of loan.
1181, 1914, s. 173.

- (a) the loan and the mode of repayment thereof ;
- (b) all lands affected by the loan ;
- (c) all the moneys collected and received in respect of the loan ;
- (d) the mode of application of the said moneys ;
- (e) all occupiers of land to whom materials have been furnished or offered to be furnished ; and
- (f) the amounts payable by each occupier.

171. (1) The Council shall—

- (a) expend the whole amount, or the whole of every instalment, of any loan, or such part thereof as is necessary, in purchasing and obtaining wire netting ;
- (b) furnish or offer to furnish the said wire netting to the occupiers of the lands in the special area proportionately to the requirements of the lands respectively ;

Loans to be used for purchase of materials for wire fencing, &c.
Ibid., s. 174.
1703, 1925, s. 66.

(c) repay

- (c) repay to the Bank any loan moneys not so expended ; and
 (d) give credit in the account-book kept by the Council, pursuant to section 170, to every such occupier of his proportion of the amount so repaid to the Bank, and reduce accordingly the proportion of the loan which the said occupier is liable to pay to the Council.

(2) When furnishing or offering to furnish wire netting to any occupier, the Council shall give notice in writing to the occupier, specifying the value thereof, and requiring him, within a time to be specified in the notice, to erect the netting on the land for which it is furnished or offered to be furnished.

(3) The said notice may be served personally or may be forwarded through the post office in an envelope addressed to the occupier at his usual or last known place of abode.

(4) The amount so specified shall thereupon become a debt due to the Council by the occupier.

(5) On the first day of February in every year one-twentieth part of the amount of the debt, together with the interest thereon and the additional sums mentioned in section 162, shall be payable by the occupier of the said land for the time being to the Council until the whole debt has been paid.

(6) Every yearly instalment shall bear interest at a rate being One Pound per centum per annum in excess of the fixed rate from the date whereon the same is hereby declared payable until actual payment ; and the said interest shall be deemed a further debt due to the Council by the occupier.

(7) The said yearly instalments and interest, and the additional sums mentioned in the said section 162, may be recovered by the Council at any time from the occupier for the time being of such land, or any part thereof, by action in any Court of competent jurisdiction or summarily.

(8) The several sums mentioned in subsection (7) hereof, as they become due, shall be, and until paid shall remain, a first charge on the land of the occupier.

(9) Any mortgagee or encumbrancee of the said land, upon default being made by the occupier in the payment of any of such sums, may pay the same to the Council, and any such payment when so made shall be deemed to be added to and to form part of the principal sum secured by the mortgage or encumbrance of the mortgagee or encumbrancee, and shall be subject to the provisions, powers, and trusts thereof.

Notice to occupiers
to erect fencing.
1181, 1914, s. 175.

172. (1) When any occupier does not within the time specified in any notice given pursuant to subsection (2) of section 171 duly erect to the satisfaction of the Council the wire netting furnished or offered to be furnished, then the Council shall undertake and carry out the erection of the netting, at the expense of the occupier, and may recover the said expense from him by action in any Court of competent jurisdiction or summarily.

(2) The

*Vermin Act.—1931.*PART V.
DIVISION II.

(2) The said expense shall until paid be a charge upon the land in connection with which the same was incurred, and may be recovered at any time from the occupier for the time being of the land or any part thereof.

173. The following provisions shall apply if an occupier within the special area refuses to accept wire netting furnished or offered to be furnished to him by the Council:—

Additional powers
of Council where
netting is refused.
Ibid., s. 176.
1703, 1925, s. 66.

- I. The Council may, without prejudice to any rights or remedies available to the Council under this Act against the occupier so refusing, offer the netting to any other occupier of land within the District of the Council:
- II. If the said other occupier accepts the offer, the Bank, if the Bank approves thereof, shall publish notice of the approval in the *Gazette*, and thereafter the said netting may be furnished to such other occupier, and he and the land in respect of which the said netting is so furnished shall become liable for the repayment of the value of the netting, together with interest thereon, and the additional sums payable therewith pursuant to section 162, in the manner and subject to the remedies hereinbefore prescribed.

174. (1) Any one or more occupiers of adjoining properties in a special area may, with the consent of the Council, instead of having dividing fences between the said lands, enclose the whole of the adjoining lands with a continuous wire netting fence.

Rights of adjoining
occupiers to enclose
with one continuous
fence.
1181, 1914, s. 177.

(2) A swing gate, at least twelve feet wide and covered with wire netting, shall be erected wherever the fence crosses a road.

175. (1) In enclosing two or more adjoining properties with one continuous wire netting fence, the fence, with the approval in writing of the Council, may be erected across any road other than a main road.

Power to fence
across certain
roads.
Ibid., s. 178.

(2) A swing gate, at least twelve feet wide and covered with wire netting, shall be erected wherever the fence crosses any such road.

(3) The Council may, by notice published in the *Gazette*, give notice of the intention of the Council to remove any fence erected across any such road, and any such fence may be removed by the Council at any time after the expiration of six months from the publication of notice as aforesaid in respect thereof.

176. (1) On the application of two or more occupiers of adjoining properties in a special area, who have been furnished by the Council with wire netting, the Council may, at the cost and on behalf of the applicants, undertake to erect, and may erect, all wire netting necessary to enclose the said properties, and also, if the Council thinks fit, any other properties, any two sides of which adjoin the same, so as to make the whole of the properties secure against the intrusion of vermin.

Power of Council to
erect fencing on
request of occupiers
Ibid., s. 179

(2) The cost of the erection may be defrayed in the first instance by the Council, but the cost shall be repaid to the Council
by

by the occupiers of the lands so enclosed in such proportions as they agree upon among themselves, or, failing agreement, as the Council finally determines.

(3) No Council shall undertake to erect any such wire netting until the occupiers concerned have entered into bonds conditioned to repay the actual cost of erecting the fencing in the manner aforesaid.

(4) The said payment shall become a charge upon the land of every such occupier, in the proportion agreed upon or determined as aforesaid, and may be recovered from the occupier for the time being of the land, or any part thereof, by action in any Court of competent jurisdiction or summarily.

Repayment of loan.
Ibid., s. 180.
1703, 1925, s. 66.

177. (1) The Council shall repay the amount lent to the Council under section 167 in twenty equal annual instalments, together with simple interest at the fixed rate, on the balance for the time being unpaid.

(2) The said repayments shall be made out of the yearly instalments received from the occupiers as aforesaid, or out of the revenue of the Council.

(3) The Council shall take all proper steps to recover all moneys due from any occupier.

(4) All such moneys received by the Council shall, within fourteen days, be paid to the Bank.

Procedure on
default by Council.
1181, 1914, s. 181.
1703, 1925, s. 66.

178. (1) When a Council fails—

(a) to pay to the Bank, as directed by subsection (4) of section 177, any moneys received by the Council; or

(b) to fully repay to the Bank, before the first day of May in every year, either by means of moneys received from occupiers or out of the revenue of the Council, one-twentieth part of any loan granted to it as aforesaid, together with the interest on the unpaid balance of the loan up to the said date,

the Bank shall make and sign a certificate to that effect.

(2) The said certificate shall be *prima facie* evidence that the sums therein mentioned are due and unpaid, and the said sums or any part thereof remaining unpaid may be deducted and paid to the Bank by the Commissioner from any subsidy granted to the Council, and shall until paid bear interest at a rate being One Pound per centum per annum in excess of the fixed rate.

(3) The Bank may thereupon apply on summons to a Judge for the appointment of a receiver or receivers, and the Judge shall thereupon appoint a person or persons (not exceeding three) to be a receiver or receivers to collect all yearly payments due to the Council in respect of wire netting.

(4) The

*Vermin Act.—1931.*PART V.
DIVISION II.

(4) The said receiver or receivers shall act under the directions of, and may be removed by, a Judge.

(5) A receiver may exercise all the powers of the Council for the purpose of collecting such payments.

179. Every receiver appointed under section 178 shall receive such remuneration for his services as a Judge directs.

Receiver's
Commission.
Ibid., s. 182.

180. Every such receiver shall apply all moneys received by him in payment of all proper costs and expenses, including his remuneration, and in payment and discharge of the whole amount due for principal and interest and additional sums under section 162 in respect of any loan made under this Act in connection with which he has been appointed receiver, and the surplus (if any) shall be paid to the Council in default.

Application of
moneys recovered
by receivers.
Ibid., s. 183.

181. Every such receiver shall have access to all books and documents under the control of the Council, and may make extracts therefrom at all reasonable times without fee.

Right of receiver to
have access to
books, &c., of the
Council.
Ibid., s. 184.

182. For the more effectual recovery of moneys due to a Council for wire netting or wire netting fencing, a Council, in addition to any powers conferred by this Act, shall also have the like powers of enforcement and recovery as are conferred on Councils with regard to unpaid rates under the District Councils Act, 1929.

Powers of recovery.
Ibid., s. 185.

183. The Council may make by-laws pursuant to the provisions of the District Councils Act, 1929, for—

Additional power to
make by-laws.
Ibid., s. 186.

- (a) apportioning the liability of occupiers of land in a special area ;
- (b) facilitating and regulating the collection and recovery of moneys due and payable to the Council pursuant to this Part ; and
- (c) generally carrying out the provisions of this Part.

184. The power of obtaining loans conferred by this Act on a Council shall be in addition to any power to borrow conferred on the Council by the District Councils Act, 1929.

Power to obtain
loans to be in
addition to power
to borrow under
District Councils
Act.
Ibid., s. 187.

185. All loans granted to a Council under this Act shall be expended by the Council to the satisfaction of the Bank.

Loans to be
expended to satis-
faction of Bank.
Ibid., s. 188.
1703, 1925, s. 66.

186. Where any money is due to a Council in respect of wire netting erected upon any land, including Crown lands, within a special area, the Council may, with the consent of the Bank, enter upon the said land and remove the said netting, and again use or dispose of the same as provided by this Part.

Power of Council to
remove wire netting.
1398, 1919, s. 8.
1703, 1925, s. 66.

PART V.

Vermin Act.—1931.

DIVISION III.

DIVISION III.—VERMIN AND DOG-PROOF FENCING BY MEANS OF LOANS TO VERMIN BOARDS.

Power to make loans for vermin-proof fencing to Vermin Boards.
1181, 1914, s. 190.
1703, 1925, s. 66.
1869, 1928, s. 4.

187. (1) A Vermin Board may borrow money from the Bank for the purpose of purchasing materials for vermin-proof fencing, dog-proof fencing, or wire netting and supplying the same to occupiers of land in a special area within the District of the Board, but not within any Municipality or District Council District.

(2) The Bank may, on the application of a Vermin Board, grant a loan to the Board for the said purpose.

(3) Every such loan shall be made out of moneys voted by Parliament for the purposes of this section.

Application of Divisions I. and II. of Part V. to Vermin Boards.
1181, 1914, s. 191.

188. The provisions of Divisions I. and II. of this Part shall apply to Vermin Boards and their respective districts, as well as to District Councils and their respective districts; and the said provisions shall be read and construed as if every reference therein—

(a) to a Council included a reference to a Board;

(b) to the Clerk of a Council included a reference to the Secretary of a Board;

(c) to a district road included a reference to any public road in the district of the Board,

and a Board may make by-laws under Division XII. of Part III. for the purposes mentioned in section 183.

Notice to debtor preliminary to exercise of special remedies given by this Division.
Ibid., s. 192.

189. (1) When any sum due to a Board under this Division is unpaid, the Board may send to the occupier by whom the same is due (hereinafter called the "debtor") a notice in the form in the Eleventh Schedule, or in a form to the like effect.

(2) The said notice shall also be published three times in the *Gazette*.

Sending of notices.
Ibid., s. 193.

190. The notice under section 189 shall be sent by post to the debtor, or to his agent or attorney in case there is any such agent or attorney resident in the State known to the Board.

Power to let land for payment of sums due.
Ibid., s. 194.

191. If after one month from the third publication as required by section 189 of the notice the sums mentioned therein as being due and payable by the debtor, or any portion thereof, remains unpaid, the Board may let the land mentioned in the notice, or any part thereof, for a year, and so on from year to year, until the said sum and all other sums payable to the Board under this Division due at the time of the letting are fully paid and discharged, and may receive and retain the rents, and apply the same in payment—

(a) in the first place, of all costs of and attending the notice, the publication thereof, and the letting; and

(b) in

*Vermin Act.—1931.*PART V.
DIVISION III.

(b) in the next place, in and towards the payment of the said sums and all other such sums as aforesaid,
and shall hold any surplus rent for the debtor.

192. (1) Instead of letting the land under section 191, the Board may apply by petition to the Supreme Court for a sale of all or any part of the land.

Power to sell land
for payment of
sums due.
Ibid., s. 195.

(2) The petition shall not, where the debtor is unknown, be presented until after one month from the third publication of the notice as required by section 191.

(3) The petition shall not, where the debtor is known, be presented until after the expiration of six months from the third publication of the said notice and service of a copy thereof or to the like effect upon the debtor or his authorised or generally recognised agent or attorney in the State by delivering the same at or sending it by post addressed to the debtor or agent, or attorney, at his last known place of abode in the State.

(4) The Court, on being satisfied by affidavit or otherwise that the moneys mentioned in the notice are lawfully due, and were owing at the time of the first publication of the notice, and that all things required by this Act to be done have been done, may make an absolute order in the first instance, or may grant a rule, calling upon the debtor, if known, or to all whom it may concern, if the debtor is unknown, to show cause why an order should not be made for the sale by public auction of the land comprised in the petition, or so much thereof as may be sufficient to pay—

- (a) the said moneys ;
- (b) any further moneys due to the Board by the debtor under this Division up to the time of the application for sale ;
- (c) all costs and expenses of and attending the notice, the publication thereof, the application, and the sale ;
- (d) all other costs, charges, and expenses of any act done or performed by the petitioners, or by their authority, for carrying out the provisions of this Division.

(5) Unless good cause is shown to the contrary within the time fixed by the rule, the Court shall order—

- (a) the sale of the land in manner aforesaid ;
- (b) payment out of the proceeds of the sale of the said moneys, costs, charges, and expenses in preference to any mortgage or other security on the land ; and
- (c) that a conveyance, or, if the property is under the provisions of the Real Property Act, 1886, a memorandum of transfer (which the Registrar-General is hereby directed to register), be executed by the Master of the Supreme Court in a form to be approved by a Judge.

No. 380 of 1886

(6) Every

PART V.
DIVISION III.

Vermin Act.—1931.

(6) Every such conveyance, or the registration of any such memorandum of transfer (as the case may be), shall vest an indefeasible estate in fee simple in the said land in the purchaser, his heirs, and assigns, free from all encumbrances.

(7) The balance arising from the proceeds of any such sale shall remain and be subject to any future or other order of the Court for the behoof of the persons interested therein.

Power to include
different lands in
one petition.
Ibid., s. 196.

193. Lands belonging to different debtors may be included in one petition for sale, and the Court may make such orders as to the apportionment of the costs and expenses of and attending the sale of the said lands, or any part thereof, as is deemed just.

Power to levy
distress.
Ibid., s. 197.

194. (1) Where any such sum as mentioned in section 189 is payable by any occupier to a Board, and remains due and unpaid for the space of one month after notice in writing to pay the same has been given to the occupier, any person by the Board thereunto authorised may, at any time thereafter, so long as any sum remains so unpaid, without any warrant, enter upon any land of the said occupier, and distrain the goods, chattels, and effects found thereon for the amount remaining due and unpaid.

(2) If the amount for which distraint is levied, together with all reasonable costs of the notice, entry, and distraint, is not paid within five days after the levy, then the said distress, or so much thereof as is sufficient to pay the amount remaining unpaid and costs, may be sold.

(3) Any surplus remaining after payment of such amount and costs, and costs of and incidental to the sale, shall be returned to the owners of the goods, chattels, and effects distrained.

Bank's receiver to
have same remedies
as the Board.
Ibid., s. 198.

195. Upon the appointment of a receiver or receivers under the provisions of section 178 (read as provided by section 188), the remedies, rights, and powers by sections 189 to 194 inclusive conferred upon a Board shall vest in the receiver or receivers, and he or they may thereafter use and exercise the same, in addition to any other remedies, rights, and powers vested in him or them: Provided that the remedies, rights, and powers conferred by section 194 may be used and exercised by the receiver or receivers personally or in manner set forth in that section.

Power of Com-
missioner to retain
instalments of loan
out of rates of the
Board.
Ibid., s. 199.
1703, 1925, s. 66.

196. When any instalment of, or interest on, an amount lent to a Board under this Division is due and has not been fully paid to the Bank, the Commissioner may from time to time apply the proceeds of any rate or rates of the Board received by him, or passing through his hands, towards the payment to the Bank of the said instalment or interest until the same is fully paid.

Preservation of
other remedies.
1181, 1914, s. 200.

197. The remedies, rights, and powers provided by sections 189 to 196 inclusive are in addition to the remedies, rights, and powers provided

*Vermin Act.—1931.*PART V.
DIVISION III.

provided by virtue of the application by section 188 of the provisions of Divisions I. and II. of this Part, and to all other remedies, rights, and powers provided by this Act or otherwise existing.

DIVISION IV.—WIRE NETTING OUTSIDE DISTRICT COUNCIL DISTRICTS AND VERMIN-FENCED DISTRICTS BY MEANS OF LOANS TO LESSEES UNDER PASTORAL AND OTHER LEASES.

DIVISION IV.

198. (1) In any case where the Bank is satisfied that any land which is not within a District Council District or a Vermin-fenced District, is occupied and that the lessee thereof is, owing to the position of the said land, unable to avail himself of the provisions of Part III., the Bank may, on the recommendation of the Pastoral Board, advance to the lessee a sum equal to the cost at the port or railway station nearest to the said land of barbed wire and netting required for making vermin-proof or dog-proof any fence on the said land.

Power to advance cost of wire and netting.
1181, 1914, s. 202.
1631, 1924, s. 4.
1703, 1925, s. 66.
1869, 1928, s. 4.

(2) All such advances shall be made out of moneys appropriated by Parliament for the purpose.

199. No sum shall be paid under section 198 until netting and barbed wire costing the amount of that sum has been actually utilised by the lessee in making the fence vermin-proof or dog-proof to the satisfaction of a Government Inspector.

Conditions of advance.
1181, 1914, s. 203.
1869, 1928, s. 4.

200. (1) All advances made by the Bank to a lessee under section 198 shall bear interest at the fixed rate.

Repayment of advances.
1181, 1914, s. 204.
1703, 1925, s. 66.

(2) The principal shall be repaid in twenty equal yearly instalments, and the principal and interest shall be recoverable as rent in arrear under the lease.

(3) If the lease in respect of which the advances are made terminates whilst any instalments remain unpaid, the remaining instalments shall be paid upon the termination of the lease, unless the incoming tenant (if any) agrees to pay the same.

(4) If the said lease is transferred or surrendered whilst any instalments remain unpaid, the remaining instalments shall be paid prior to the transfer or surrender, unless the incoming tenant (if any) agrees to pay the same.

(5) The amount of any instalments remaining unpaid may be repaid by the lessee at any time.

(6) Any instalment which is unpaid for fourteen days after the due date thereof shall, by way of penalty, bear interest, payable therewith, and calculated at a rate being One Pound per centum per annum in excess of the fixed rate.

201. All barbed wire and netting by which a fence, the property of the Crown, is made vermin-proof or dog-proof by the lessee at his own cost, shall remain the property of the lessee, and shall at the

Wire and netting to be paid for by incoming lessee.
1181, 1914, s. 205.
1631, 1924, s. 5.
1869, 1928, s. 4.

PART V.
DIVISION IV.

Vermin Act.—1931.

the termination of his pastoral lease, be valued as provided by the Pastoral Act, 1904, and be paid for by the incoming lessee.

DIVISION V.

DIVISION V.—CONTRIBUTION TO VERMIN, DOG-PROOF, AND RABBIT-PROOF FENCES BY ADJOINING OCCUPIERS.

Liability of occupiers to contribute to cost of fence.
1181, 1914, s. 206.
1869, 1928, s. 4.

202. Where an occupier of land not within a District Council District or Municipality erects, whether before or after the passing of this Act, a vermin fence or a dog-proof fence upon the boundary or any part of the boundary of the said land, the occupier of the adjoining land shall, three months after demand upon him, be liable to contribute towards the cost of erecting the said fence to the extent of one-half of the value thereof at the time when the demand is made: Provided, however, that if the land occupied by the person from whom contribution is sought is not by means of the erection of the said fence or otherwise enclosed, either by itself or together with lands occupied by any other person or persons, by a vermin fence, a dog-proof fence, or a rabbit-proof fence, or partly by one and partly by the other, the amount which the said person shall be liable to contribute shall be limited to one-fourth of the value of the fence at the time of the demand being made; and a further one-fourth of the value of the fence shall become payable by the said person immediately upon the land occupied by him becoming so enclosed.

Payment for boundary fences.
1181, 1914, s. 207.
1869, 1928, s. 5.

203. (1) Where an occupier of land within a District Council District or Municipality erects, whether before or after the passing of this Act, a rabbit-proof fence upon the boundary of the said land the occupier of the adjoining land shall, after demand, be liable to pay to the occupier of the first-mentioned land who is in occupation thereof at the time when the demand is made a contribution in respect of the fence, calculated as follows:—

- I. If the adjoining land is within a District Council District or Municipality, the contribution shall be one-half of the value of the fence at the time of the demand:
- II. If the adjoining land is not within a District Council District or Municipality, the contribution shall be calculated and be payable in manner provided by section 202.

(2) Contributions under subdivision I. of subsection (1) hereof shall be paid within one year from the date of demand, with interest at the rate of Six Pounds per centum per annum.

Notice to adjoining occupier of intention to erect fence.
1181, 1914, s. 208.
1869, 1928, s. 4.

204. (1) As regards any vermin fence, dog-proof fence, or rabbit-proof fence erected after the second day of January, nineteen hundred and six, an occupier requiring any adjoining occupier to join in or contribute towards the erection of the fence shall serve on the adjoining occupier a notice of his intention to fence specifying the boundary to be fenced and the kind of fence proposed to be erected.

(2) If

*Vermin Act.—1931.*PART V.
DIVISION V.

(2) If within three months after the service of the notice the occupier serving the notice and the occupier served therewith do not agree as to the erection and the kind of fence to be erected, the occupier serving the notice may erect the whole fence, and may recover from the occupier from whom contribution is sought the proportion of the cost of the erection to which the last-mentioned occupier is liable under this Part.

205. If the occupier of any land bounded by a road erects, whether before or after the passing of this Act, on the boundary of his land and the said road—

Payment by adjoining owner where land bounded by road.

1181, 1914, s. 209.
1869, 1928, ss 4 and 6.

(a) a rabbit-proof fence, if the land is situated within a District Council District; or

(b) a vermin fence or a dog-proof fence, if the land is not situated within a District Council District,

and any other occupier adopts, whether before or after the passing of this Act, any means whereby his land is enclosed by the said fence, the last-mentioned occupier shall, three months after demand upon him, be liable to pay to the occupier of the land whereon the said fence is erected interest on the half value of the fence at the time of the demand at the rate of Eight Pounds per centum per annum, for so long as the land of the occupier upon whom the demand is made is so enclosed, the said interest being payable annually, and shall also for so long as aforesaid be further liable for half the cost of the repairs to the fence.

206. (1) Any person erecting a vermin fence, a dog-proof fence, or a rabbit-proof fence shall be entitled to clear all scrub for a width not exceeding six feet on each side along the length of the fence.

Scrub clearing to be deemed part of cost of fence.

1181, 1914, s. 210.
1869, 1928, s. 4.

(2) The cost of any such clearing shall be deemed to be a part of the cost of erecting the fence, and the cost of keeping the said width clear shall be deemed to be part of the cost of repairing the fence.

207. When and as often as any vermin fence, dog-proof fence, or rabbit-proof fence, whether erected before or after the passing of this Act, is out of repair or requires renewal, the occupiers of land on either side thereof shall be liable to contribute towards the cost of repairing or renewing the fence in equal proportions.

Liability of occupiers for cost of repairs.

1181, 1914, s. 211.
1869, 1928, s. 4.

208. (1) The occupier of any land separated from any adjoining land by a vermin fence, dog-proof fence, or rabbit-proof fence may, in manner provided by section 213, serve a notice upon the occupier of the adjoining land requiring him to assist in repairing or renewing the fence.

By whom repairs to be effected.

1181, 1914, s. 212.
1869, 1928, s. 4.

(2) If the last-mentioned occupier fails to comply with the notice for the space of fourteen days after the service thereof, the first-mentioned occupier may repair or renew the fence and demand and recover of and from the other occupier the proportion of the cost of repairing or renewing the same to which he is liable under the provisions of section 207.

(3) If

(3) If any such fence, or any portion thereof is destroyed or injured by accident, the occupier of the land on either side thereof may immediately repair or renew the same without any notice to the other occupier, and shall be entitled to recover the proportion mentioned in subsection (2) hereof of the cost of so doing from the occupier of the adjoining land.

(4) Notwithstanding anything in this section, in case any such fence is injured or destroyed in whole or in part through the neglect of any occupier of adjoining land, the occupier through whose neglect the fence is so injured or destroyed shall, at his own expense, repair or renew the fence so injured or destroyed ; and on default the other occupier may repair or renew the same and demand and recover from the occupier so liable the entire cost of the repair or renewal.

Explanation of provisions in this Division.
1181, 1914, s. 213.
1869, 1928, ss. 4 and 7.

209. For the purposes of this Division—

- (a) land shall be deemed to be enclosed when at least three-fourths of the total length of the boundaries thereof are fenced with a vermin fence, dog-proof fence, or a rabbit-proof fence ;
- (b) words referring to the erection of a vermin fence, dog-proof fence, or a rabbit-proof fence shall include the making of an existing fence vermin proof, dog proof, or rabbit proof ;
- (c) as regards lands which are held under lease from or agreement with the Crown, it shall be sufficient if any fence is a boundary fence, or if, although not actually upon a boundary, it serves the purpose of a boundary fence in the opinion of—
 - (i.) the Pastoral Board, as regards land included in a pastoral lease ; or
 - (ii.) the Commissioner, as regards land included in any other lease from or agreement with the Crown ;
- (d) as regards lands to which the next preceding subdivision is inapplicable the following provisions shall apply :—
 - I. When adjoining occupiers have not agreed as to the accurate position of the boundary line between their respective holdings on which either of such occupiers proposes that a vermin fence, dog-proof fence, or a rabbit-proof fence shall be erected, the said occupier may give notice to the other occupier of his intention to have the boundary fence defined by a licensed surveyor :
 - II. The occupier to whom any such notice has been given shall, seven days after the service thereof—
 - (i.) if satisfied as to the accurate position of the boundary line, define the same by pegs ; or
 - (ii.) employ

Vermin Act.—1931.PART V.
DIVISION V.

(ii.) employ a licensed surveyor to define the boundary line ;

and shall in either of such cases notify, by writing, the other adjoining occupier of his action in the matter :

III. If for one month from the service of the said notice, the occupier to whom the notice has been given has failed to—

(i.) define the boundary line by pegs ; or

(ii.) have the boundary line defined by a licensed surveyor ;

then the occupier proposing to erect the fence may have the boundary line defined by a licensed surveyor :

IV. If the boundary line when defined by a licensed surveyor is ascertained to be in the same position as defined by any pegs placed there by the occupier to whom the notice has been given, that occupier shall not be liable for any part of the costs of the survey ; but in all other cases where a licensed surveyor has been employed all reasonable expenses incurred shall be paid by the adjoining occupiers in equal shares.

DIVISION VI.—MISCELLANEOUS.

DIVISION VI.

210. Nothing in this Part contained shall be deemed or taken to affect any covenant, contract, or agreement made before or after the passing of this Act relative to any vermin fence, dog-proof fence, or rabbit-proof fence between landlord and tenant or between occupiers of adjoining lands.

Covenants, contracts, or agreements not affected.
1181, 1914, s. 214.
1869, 1928, s. 4.

211. Every person engaged in erecting, renewing, or repairing a vermin fence, dog-proof fence, or rabbit-proof fence under this Part, his agents and servants, may, with or without horses, cattle, carts or carriages, at all reasonable times while the erection, renewal, or repairing is proceeding, enter upon the lands adjoining the fence and clear the scrub, and do thereon such acts, matters and things, except the cutting and felling of timber (other than such scrub), as may be necessary for carrying into effect the erection, renewal, or repair of the fence.

Right of entry for repairs, &c.
1181, 1914, s. 215.
1869, 1928, s. 4.

212. Any person may come in and defend any proceeding under this Part against any tenant of that person in consequence of which the said person may ultimately incur any liability ; and any defence which the person originally proceeded against might set up shall be available to the person so coming in to defend.

Power of landlord to defend proceedings.
1181, 1914, s. 216.

213. (1) Any

PART V.
DIVISION VI.

Vermin Act.—1931.

Notice.
Ibid., s. 217.

213. (1) Any notice or demand to be given or made under this Part may—

- (a) be in writing or in print, or partly in writing and partly in print ;
- (b) be signed by the person giving or making the same, or by his attorney or agent ; and
- (c) be served on any person resident upon the land in question, or if there is no such person, or such person cannot be discovered, then on the occupier or occupiers of the land, or one of them, either personally or by leaving the same at, or by forwarding the same through the post office in an envelope addressed to him or them at, his or their usual or last known place of abode or business in the State, and if there is no such occupier residing in the State the service of the notice or demand may be dispensed with.

(2) Any person entitled to any such notice or demand may by words or conduct waive the same.

Sum to be recovered.
Ibid., s. 218.

214. No greater sum shall be recovered from any person under this Part for the cost of erecting, repairing, or renewing any fence than the amount which would have been payable if the fence had been an ordinary fence of its kind, and had been erected, repaired, or renewed for the price usually paid in the district or locality wherein the fence is situated for erecting, repairing, or renewing such a fence at the time when the sum sought to be recovered first became payable.

Person receiving
advance to allow
similar credit.
Ibid., s. 219.

215. Any person who has received an advance for fencing under this Act shall, until the advance has been repaid, allow to any person from whom he is entitled to recover any portion of the cost of the fence, such credit as he is himself entitled to under this Act.

PART VI.

PART VI.

MISCELLANEOUS PROVISIONS.

Power of the Bank
to fix the rate of
interest on loans.
1181, 1914, s. 220.
1703, 1925, s. 66.

216. (1) The Bank may, from time to time, by notice published in the *Gazette*, fix the annual rate of interest to be paid on loans and advances made by the Bank and sums expended by the Commissioner or the Bank under this Act, and may, in like manner, annul any rate so fixed.

(2) Any rate so fixed shall come into force on the fourteenth day after the date of the *Gazette* in which the same is published, and shall continue in force until the fourteenth day after the date of the *Gazette* in which the notice annulling the same is published.

217. (1) The

Vermin Act.—1931.

PART VI.

217. (1) The cost of any advertisement required by Part III. shall be paid by the Board, Council, or person whose action immediately necessitated the advertisement.

Cost of advertisements.
1181, 1914, s. 221.

(2) The Commissioner may require payment of any such cost before causing an advertisement to be inserted.

218. It shall be sufficient in any notice required under this Act if the notice clearly and reasonably states the purpose thereof.

Sufficiency of notice if purpose clearly stated.

Ibid., s. 222.

219. Subject to section 213, the following provisions shall apply as to every notice or demand by this Act required to be given to or made on the owner or occupier of any land :—

Service of notices and demands.

Ibid., s. 223.

1249, 1916, s. 4.

1567, 1923, s. 11.

1990, 1930, s. 4.

I. Every notice or demand shall be addressed to the said owner or occupier :

II. Every such notice or demand shall be deemed duly served if the same has been—

(a) given to the owner or occupier personally ;

(b) left at his usual or last known place of abode ; or

(c) sent by post, in a prepaid envelope addressed to the owner or occupier at his usual or last known place of abode ; in which case service shall be deemed to have been effected (unless the contrary is proved) at the time when the letter would be delivered in the ordinary course of post, or, in cases where there is no delivery by letter carriers, would be ready for delivery if called for at the post office of destination :

III. In the case of the Crown all notices shall be sent by post to the Director of Lands :

IV. Where there is more than one owner or occupier of the same land, service upon any one of them in manner aforesaid shall be deemed service upon all.

220. Every summons, notice, writ, or other process required or authorised to be served on a Board may be served by being given personally to the Chairman or Secretary, or at the Vermin Board Office to some officer of the Board there.

Service of notices and legal proceedings on Board.
1181, 1914, s. 224.

221. Every order, summons, notice, or other such document requiring to be authenticated by a Board shall be sufficiently authenticated without the common seal of the Board if signed by the Chairman, or two members of the Board, or the Secretary.

Authentication of certain documents by the Board.
Ibid., s. 225.

222. (1) In any case where—

(a) a loan has, before the sixteenth day of October, nineteen hundred and thirty, been made to a Vermin Board under

Power to extend time for certain repayments.
1955, 1930, s. 3.

Division

Division X. of Part III. or Division III. of Part VI. of the Vermin Act, 1914, or to a lessee of land under Division IV. of the said Part VI. ; and

- (b) at least fourteen annual instalments in respect of the said loan will become due and payable after the sixteenth day of October, nineteen hundred and thirty,

the Bank may on application in writing made within twelve months from the sixteenth day of October, nineteen hundred and thirty, by the Board or lessee, as the case may be, extend the period for the repayment of the said loan for such time as the Bank thinks fit, but so that the total time for repayment thereof from the date upon which the loan was originally made (including any period for suspension of repayments granted pursuant to section 223) shall not exceed forty-two years, and, in the case of a loan to a lessee, so that the said time for repayment so extended shall expire on or before the expiration of the term of the lease of the lessee.

(2) Upon any such extension, the balance of the loan, together with interest at the fixed rate on the balance of the loan for the time being unpaid, shall be repaid by such equal annual instalments spread over the remainder of the term of the loan as are fixed by the Bank.

(3) The Bank may require payment to be made of any arrears of instalments or interest in respect of any such loan or of any part of any such arrears before extending the period in respect of the loan under subsection (1) hereof, or the Bank may capitalize the said amount of arrears, or, as the case may be, the part not required to be paid as aforesaid, and any such arrears so capitalized shall be paid to the Bank within such time and upon such terms as the Bank thinks fit. In every such case the said arrears shall bear interest at such rate as is determined by the Bank.

(4) When the Bank has granted an extension under this section to any Vermin Board with respect to a loan, the obligations on the part of occupiers and other persons as to payments falling due to the Board in respect of fencing material furnished by the Board to the said occupiers by means of the loan, shall be extended for the same period and subject to the same conditions as to repayment of instalments, interest, and arrears as the obligations of the Board in respect of the loan are extended.

Power to suspend
certain repayments.
Ibid., s. 4.

223. (1) In this section—

“ Lessee ” means lessee to whom an advance has been made under section 202 of the Vermin Act, 1914, or under the corresponding provision of any Act thereby repealed :

“ Loan ” includes an amount expended, or an amount advanced, under Part IV. or section 202 of the Vermin Act, 1914, or under the provisions corresponding thereto respectively of any Act thereby repealed, as well as a loan to a District Council, Vermin Board, or Vermin Trust.

(2) Notwithstanding

Vermin Act.—1931.

PART VI.

(2) Notwithstanding anything contained in this Act, the Commissioner, on the recommendation of the Bank may, subject as hereinafter provided, suspend the operation of the provisions of this Act requiring the repayment by District Councils, Vermin Boards, Vermin Trusts, and lessees respectively of instalments of loans granted to them prior to the first day of February, nineteen hundred and thirty, under the Vermin Act, 1914, or any Act thereby repealed, during such period as he thinks fit; and the Commissioner may, subject as aforesaid, and upon the said recommendation, from time to time extend the suspension for a further period.

(3) Any period of suspension under this section—

(a) may commence from any date not earlier than the first day of January, nineteen hundred and thirty:

(b) shall, with all (if any) extensions thereof, expire not later than the thirty-first day of December, nineteen hundred and thirty-two, and not exceed two years.

(4) The power hereby conferred on the Commissioner may be exercised in the case of any District Council, Vermin Board, Vermin Trust, or lessee which or who makes application in writing to the Commissioner in that behalf: Provided that the District Council, Vermin Board, Vermin Trust, or lessee shall satisfy the Commissioner, by such evidence as the Commissioner may require, that it or he is unable, by reason of the effects of the recent drought, to pay its or his instalments of principal and interest due in respect of the loan at the times and in the manner provided by this Act.

(5) Interest at such rate as is fixed by the Commissioner on the recommendation of the Bank on the amount of the loan unpaid at the time of the commencement of the period of suspension shall be payable during the period of suspension. The said interest shall be paid at such times after the expiration of the period of suspension as are fixed by the Commissioner on the recommendation of the Bank, and shall for all purposes be deemed to be an instalment payable under this Act.

(6) When the provisions of this Act mentioned in subsection (2) hereof have been suspended as therein provided in the case of any District Council, Vermin Board, Vermin Trust, or lessee, the Council, Board, Trust, or lessee shall not be liable, during the period of suspension, to make any payment on account of principal or interest due in respect of the loan to which the suspension applies.

(7) The Commissioner may, if he thinks fit, for the purposes of subsection (2) hereof, fix periods of suspension of different lengths in the case of different District Councils, Vermin Boards, Vermin Trusts, or lessees.

(8) A period equal in length to the period of suspension fixed by the Commissioner under this section in the case of any loan shall be added to the period within which the loan is required by this Act to be repaid; and every instalment of the principal moneys payable on account of the loan, and interest on the moneys, which

PART VI.

Vermin Act.—1931.

which, but for the provisions of this section, would have been payable on some date during the period of suspension, shall be payable upon the corresponding date in the added period; and the suspension shall not alter the dates upon which the other instalments and interest fall due.

When liability of District Council, etc., suspended, suspension to extend to occupiers.
Ibid., s. 5.

224. (1) When the Commissioner has granted a suspension under section 223 to any District Council, Vermin Board, or Vermin Trust, with respect to any loan, the obligations on the part of occupiers and other persons as to payments falling due with respect to the loan, during the period of suspension, shall be suspended for the same period, but interest on the loan as provided by subsection (5) of section 223 shall be payable in manner provided by the said subsection.

(2) Any payment which, but for this section, an occupier or other person would have been liable to make on some date during a period of suspension shall be made by the occupier or person on the corresponding date in the added period referred to in subsection (8) of section 223.

Vermin Trusts,
Ibid., s. 20.

225. Notwithstanding the repeal of Part IV. of the Vermin Act, 1914—

- (a) the members of every Vermin Trust constituted or continued in pursuance of the said Part shall be under the same liability to repay all sums granted and paid to the members or the Vermin Trust and interest thereon as if the provisions of the said Part IV. had continued in full force and effect, and for the purposes of securing payment as aforesaid the provisions of the said Part shall, notwithstanding the repeal thereof, be deemed to be in full force and effect; and
- (b) every such Vermin Trust shall continue until such time as the sums granted and paid to the Vermin Trust and its members and interest thereon are paid, and no longer.

PART VII.

PART VII.

ENFORCEMENT OF THE ACT.

DIVISION I.

DIVISION I.—OFFENCES.

Persons examined on oath, &c., making false statement, guilty of perjury.
1181, 1914, s. 226.
1955, 1930, s. 21.

226. Every person who is examined upon oath, affirmation, or declaration, by any Court or Board, or any Justice or other person under the authority of this Act, and who, upon such examination, wilfully makes any false statement, or who wilfully makes any false statement in any declaration made pursuant to section 163, shall be guilty of wilful and corrupt perjury, and shall be punished accordingly.

227. Every

*Vermin Act.—1931.*PART VII.
DIVISION I.

227. Every person who forges or alters, or utters, uses, disposes of, or puts off, knowing the same to be forged or altered, any document or writing required or authorised by this Act, or any signature thereto or seal thereon, shall be guilty of felony, and shall be liable to be imprisoned for any term not exceeding seven years.

Forgery.
1181, 1914, s. 227.

228. Every person who—

- (a) wilfully publishes in the *Gazette* any false notice or other document in any matter in which a notice or other document is by this Act required or authorised to be published in the *Gazette*; or
- (b) wilfully posts any false notice in any matter of which public notice or any notice is by this Act required to be given; or
- (c) tears down, mutilates, defaces, or obliterates any public notice or other document posted in any place under the authority of this Act,

Persons publishing false statements in *Gazette* liable to fine.
Ibid., s. 228.

shall be liable to a penalty not less than One Pound nor more than Ten Pounds.

229. Any person who destroys or injures any vermin fence, dog-proof fence, or wire netting fence, or any part thereof, or any gate therein, shall be liable to a penalty not exceeding Twenty Pounds, or to be imprisoned for a term not exceeding six months.

Penalty for destroying or injuring fence.
Ibid., s. 229.
1869, 1928, s. 4.

230. Any person who—

- (a) passing through a gateway in any vermin fence, dog-proof fence, or rabbit-proof fence, leaves the gate thereof open; or
- (b) opens and leaves open a gate in any such fence,

Penalty for leaving gate open.
1181, 1914, s. 230.
1869, 1928, s. 8.

shall be liable to a penalty not exceeding Fifty Pounds, and in default of payment to be imprisoned for a term not exceeding six months.

231. Any person who falsely represents himself to be an authorised person either by giving a notice to an owner or occupier purporting to be a notice under Part II., or in any other manner howsoever personating an authorised person, shall be guilty of a misdemeanour, and shall be liable to be imprisoned for any period not exceeding twelve months; and shall, in addition to the said imprisonment, be liable to a penalty not less than Twenty Pounds nor more than One Hundred Pounds.

Penalty for personating officers.
1181, 1914, s. 231.

232. (1) Any person who—

- (a) wilfully obstructs, hinders, or interrupts an authorised person in the exercise of a power or authority vested in the authorised person by Part II.; or

Penalty for obstructing authorised person.
Ibid., s. 232.

(b) threatens

(b) threatens, assaults, or uses improper language to an authorised person whilst in the performance of his duty,

shall be liable to a penalty not exceeding Twenty Pounds.

(2) No proceeding for the recovery of any such penalty, nor the payment thereof, shall be a bar to an action at law by any such authorised person for or in respect of any such assault.

Penalty for letting loose vermin.
Ibid., s. 233.

233. Any person who lets loose any vermin, or permits any vermin to be let loose in any part of the State shall be liable to a penalty for every offence not exceeding One Hundred Pounds or to be imprisoned for a term not exceeding six months.

Penalty for letting loose vermin on Kangaroo Island or any of the other islands on the coast of South Australia.
Ibid., s. 234.

234. Any person who—

(a) imports into or lets loose on Kangaroo Island, or any of the other islands on the coast of the State; or

(b) permits to be let loose on any of those islands; or

(c) keeps alive on any vessel touching any of those islands,

any vermin, shall be liable to a penalty of One Hundred Pounds, or to be imprisoned for a term not exceeding six months.

Penalty for disqualified person acting as member or auditor.
Ibid., s. 235.

235. Every person who—

(a) at the time of his appointment or election as a member of a Board or an auditor is to his knowledge, disqualified to act in that office; or

(b) in any manner acts as a member of a Board or as an auditor knowing that he has become disqualified so to act,

shall be liable to a penalty not exceeding Ten Pounds.

Penalty for not giving notice of disqualification.
Ibid., s. 236.

236. Every person appointed or elected to the office of member of a Board or of auditor, who at the time of his appointment or election is disqualified, or who after his appointment or election becomes disqualified, and who does not within fourteen days after becoming aware of his appointment or election and the existence of his disqualification, deliver or send through the post to the Chairman of the Board, or, if there is no Chairman, to the Commissioner, a notice containing his resignation, with the grounds thereof, shall be liable to a penalty not exceeding Ten Pounds.

Penalty for failing to defend title to the office.
Ibid., s. 237.

237. Every member of a Board who, being duly qualified and duly elected or appointed, is called upon in manner by Division III. of this Part prescribed to defend his title to his office, and by default, or in collusion with any person laying the complaint against him, suffers an order to be made declaring his seat to be vacant, or that he is not a member, shall be liable to a penalty not exceeding Twenty Pounds.

238. Every

*Vermin Act.—1931.*PART VII.
DIVISION I.

238. Every person under eighteen years of age who votes at an election held under Part III., or sits or acts as a member of a Board, shall be liable to a penalty not exceeding Ten Pounds.

Penalty on minors voting or acting as members.

Ibid., s. 238.

239. Every person who—

- (a) gives any money or article to a voter with a view to influencing his vote;
- (b) holds out to a voter any promise or expectation of individual profit, advancement, or enrichment in any shape in order to influence his vote; or
- (c) makes use of any threat to a voter with a view to influencing his vote;

Penalty on persons bribing voters and on voters accepting bribes.

Ibid., s. 239.

and every voter who—

- (d) receives any money or article for his vote; or
- (e) in consequence of any promise of profit, advancement, or enrichment promises his vote,

shall be guilty of a misdemeanour and be liable to a penalty of not less than Ten Pounds nor more than Twenty-five Pounds, or to be imprisoned for any period not exceeding three months.

240. Every person who wilfully makes any false answer to any question put to him under Part III. by any officer or person having authority in that behalf touching any voting-paper tendered by the said person, or the right of the said person to vote, shall be guilty of a misdemeanour, and shall be liable to be imprisoned for a period not exceeding twelve months.

Persons making false answers to questions as to voting at elections guilty of misdemeanour.

Ibid., s. 240.

241. Every officer or other person who is entrusted with, or who receives money under this Act, or by virtue of any office to which he is appointed, or by virtue of any duty confided in him by a Board, and fraudulently disposes of or retains in his possession or applies to his own use the said money, or any part thereof, shall be deemed to have stolen the same and shall be guilty of larceny.

Officer misappropriating money guilty of larceny.

Ibid., s. 241.

242. Every person who obstructs a Board, or any officer or person employed by it in the performance of anything which it or he is empowered by this Act to do, shall be liable to a penalty not exceeding Five Pounds.

Penalty for obstructing Board, officers, etc.

Ibid., s. 242.

243. Where any matter or thing is by or under Part III., or by any order or notice made and published under the authority of this Act directed or forbidden to be done, or where under any authority given by Part III. to any person any matter or thing is directed to be done, or is forbidden to be done, and the act so directed to be done remains undone, or the act so forbidden to be done, is done, in every such case every person offending against the direction or prohibition shall be deemed to be guilty of an offence against Part III.

Non-observance of any direction or prohibition of or under the Act.

Ibid., s. 243.

244. Every

PART VII.
DIVISION I.

Vermin Act.—1931.

Penalty for offence against Part III. of this Act.

Ibid., s. 244.

244. Every person guilty of an offence against Part III. shall, for every such offence, be liable to the penalty expressly imposed by the said Part III. or by any by-law in force in that behalf, and, if no penalty is so imposed, to a penalty not exceeding Twenty Pounds.

Failure to erect wire netting or using same for improper purpose.

Ibid., s. 245.

1955, 1930, s. 22.

245. Any occupier (within the meaning of Part V.) who fails to comply with a notice given pursuant to subsection (2) of section 171, and any person who uses any wire netting furnished by a Council, a Board, or the Bank under subsection (1) of section 171 for any purpose other than the purpose for which it was so furnished, shall be liable to a penalty not exceeding Twenty Pounds.

Non-compliance with notice to repair fence.

1181, 1914, s. 246.

246. Any owner or occupier who does not, within fourteen days after service upon him by a District Council or Vermin Trust of a notice requiring him to repair a wire netting fence erected upon his land under the provisions of this Act or of any repealed Act, or any gate therein, or to keep any such fence or gate clear of sand, rubbish, or other accumulation, duly comply with the notice, shall be liable to a penalty not exceeding Twenty Pounds.

DIVISION II.

DIVISION II.—EVIDENCE.

Gazette conclusive evidence of proclamation and *prima facie* evidence of facts stated therein.

Ibid., s. 247.

247. (1) A copy of the *Gazette* containing a proclamation made by the Governor or by the Commissioner under this Act or any repealed Act shall be conclusive evidence of the fact, tenor, and validity of the proclamation, and shall be evidence of the facts stated, recited, or assumed therein.

(2) No such proclamation shall be invalid by reason of anything required as preliminary thereto not having been duly done.

Gazette evidence of appointments and elections notified therein.

Ibid., s. 248.

248. A copy of the *Gazette* containing a notice of the appointment or election of any person to any office in a District shall be conclusive evidence of that appointment or election, except in any proceeding brought to try the title of the person so appointed or elected.

Gazette evidence of resolution of Board notified therein.

Ibid., s. 249.

249. A copy of the *Gazette* containing a notice that a resolution was passed or an order was made at a meeting of a Board shall be conclusive evidence—

(a) of the resolution having been passed or the order having been made:

(b) of the meeting having been lawfully convened:

(c) of any facts stated in the notice relating to the majority by which the resolution was passed, and the number and proportion of members of the Board present.

Gazette containing notice of the making of a rate conclusive evidence.

Ibid., s. 250.

250. A copy of the *Gazette* containing a notice that a rate declared by a Board is payable shall, except on proceedings to quash the rate, be conclusive evidence that the rate has been duly declared or made.

251. By-laws,

*Vermin Act.—1931.*PART VII.
DIVISION II.

251. By-laws, minutes of a Board or a committee thereof, books and contracts, specifications, plans, estimates, and other documents by this Act required or authorised, which are in the hands of a Board, and any copy thereof or extract therefrom respectively which purports to be signed by the Chairman, or two members of the Board, or the Secretary, shall be receivable in any proceeding before any Court or person as evidence of the matters therein contained, and, in the case of by-laws, shall be evidence of the passing, confirmation, and publication thereof, and of the performance of the requirements of this Act in respect thereto.

By-laws, minutes, contracts, &c., or certified copies, evidence.
Ibid., s. 251.

252. Judicial notice shall be taken of the seal of a Board by every Court and every Justice.

Judicial notice of seal.
Ibid., s. 252.

253. Nothing in this Act contained shall—

- (a) prevent proof being given of the tenure by any person of any office by evidence that the said person acted in that office :
- (b) prevent any notice purporting to be a notice given by a Board and published or posted as by this Act directed, or a copy thereof, being given in evidence in any proceeding against the Board, or any officer thereof :
- (c) negative any statutory or other rule of law as to evidence or any presumption arising therefrom.

Saving of rules of evidence.
Ibid., s. 253.

254. In any proceedings for the recovery of the cost and expense of destroying vermin under Part II., a certificate purporting to be under the seal of the Council or Vermin Board, or under the hand of the Chairman of an Associated Board, or of the Commissioner (as the case may require), and specifying the amount of the cost and expense of such destruction, shall be received as *prima facie* evidence of the amount of the said cost and expense.

Certificates *prima facie* evidence of cost of destruction.
Ibid., s. 254.

255. (1) A copy of the *Gazette* containing any regulations purporting to be made by the Governor by virtue of this Act, or of any Act hereby repealed, shall be conclusive evidence of the making of the regulations.

Gazette conclusive evidence of regulations, and also of either House objecting to them.
Ibid., s. 255.

(2) A copy of the *Gazette* containing a notice that a resolution has been passed by either House of Parliament objecting to any such regulations shall be conclusive evidence of the passing of the resolution.

256. In any proceeding where it is desired to prove the amount of any payments due at the time of the proceeding or thereafter payable under Part V. in respect of any land, a certificate as to the amount, signed by the Bank, by the Secretary to the Board, or by the Clerk of the Council (as the case may require) shall be *prima facie* evidence as to the amount,

Evidence of moneys owing on land.
Ibid., s. 256.
1955, 1930, s. 23.

257. (1) In

PART VII.
DIVISION II.

Vermin Act.—1931.

Certain allegations
prima facie proof.
1567, 1923, s. 12.
1955, 1930, s. 26.

257. (1) In any proceedings for an offence against this Act, the production of any writing purporting to be an authorisation and appointment by any District Council, Vermin Board, or Associated Board, or by the Commissioner, of any person by the name of the complainant to be an authorised person shall be *prima facie* evidence that the complainant is an authorised person authorised and appointed by the District Council, Vermin Board, or Associated Board mentioned in the writing, or by the Commissioner, as the case may be.

(2) In any proceedings for an offence against this Act, any allegation in the complaint—

(a) that any Crown lands or any other land mentioned in the complaint are situated within any specified District Council District or Vermin-Fenced District or are not situated within any District Council District or Vermin-Fenced District ;

(b) that any person mentioned in the complaint is the owner or occupier of any land ; or

(c) that any road or land mentioned in the complaint adjoins any land,

shall be *prima facie* evidence of the truth of the matters so alleged.

DIVISION III.

DIVISION III.—LEGAL PROCEDURE.

Representation of
Board in cases of
bankruptcy.
1181, 1914, s. 257.

258. In the event of any person against whom a Board has any claim or demand being adjudicated bankrupt, or making a statutory assignment for the benefit of, or a composition with, his creditors, the Secretary, treasurer, or any other officer of the Board, appointed by the Chairman, in writing under his hand, may represent the Board in all proceedings relating to the bankruptcy or assignment or composition of the said person, as if the claim or demand had been the claim or demand of the Secretary, treasurer, or officer.

Representation of
Board before Court
of Summary Juris-
diction and in
Local Court.
Ibid., s. 258.

259. In all proceedings before a Court of Summary Jurisdiction or a Local Court, the Secretary, treasurer, or any other officer of the Board, appointed by the Chairman in writing under his hand, may represent the Board in all respects, as though the said officer had been the party concerned.

Reimbursement of
officer.
Ibid., s. 259.

260. The Secretary, treasurer, or other officer, appointed as provided by section 258 or 259, shall be reimbursed out of the District Fund all damages, costs, charges and expenses to which he may be put or with which he may become chargeable by reason of anything done under the authority of either of those sections.

Power to correct
informalities of
notices and com-
plaints.
Ibid., s. 260.

261. (1) It shall be sufficient in any complaint under this Act if the complaint gives the accused a reasonably clear and intelligent statement of the offence with which he is charged.

(2) No conviction shall be held void or invalid or be quashed for any defect in substance or form therein.

(3) The

Vermin Act.—1931.PART VII.
DIVISION III.

(3) The Court shall amend or permit the amendment of every complaint which in its opinion is defective.

262. No writ of *quo warranto*, or information in the nature of a *quo warranto*, or any other process shall issue from, or be filed, or had, or taken in, the Supreme Court, to try or question the title of any Board, or the title of any person to act as a member or Chairman of a Board, or as an auditor for any District, or in any office or place in the gift of a Board.

No writ of *quo warranto* allowed to try title to any office.

Ibid., s. 261.

263. No *mandamus* shall issue from the Supreme Court to admit or restore to office, or to compel a Board to proceed to the election of, any member or Chairman of the Board, or of any auditor for the District, or to the appointment of any officer of the Board or of any person to any office or place in the gift of the Board, or to compel the production or delivery of any books, voting-papers, or other documents or papers, to the production or possession whereof the Board or any person is entitled under this Act.

No *mandamus* to issue from Supreme Court to compel Board to admit, restore, or elect members.

Ibid., s. 262.

264. The proceedings—

- (a) to try the title of a member or Chairman of a Board, or of an auditor, or of an officer or other person holding a place in the gift of a Board, to his office or place ;
- (b) to try the right of any person to be admitted or restored to any such office or place, or to compel his admission or restoration thereto ;
- (c) to compel the Board to proceed to any election or appointment ;
- (d) to try the validity of any rate ; or
- (e) to compel the production or delivery of any books, voting-papers or other documents or papers to the production or possession whereof the Board or any person is entitled under this Act,

Summary proceedings for trying title of member of Board, &c., to his office.

Ibid., s. 263.

shall be had and determined summarily.

265. (1) A complaint for the purposes of section 264 may be laid at the instance of the Board, or by a ratepayer of the District, or by the Commissioner or any other person interested.

Jurisdiction of Court of Summary Jurisdiction.

Ibid., s. 264.

(2) The Court of Summary Jurisdiction may make an order—

- (a) declaring any person to be not entitled to the office or place then held by him, and that the office or place is vacant :
- (b) declaring that the complainant is entitled to the said office or place :
- (c) commanding the Board to proceed to take the necessary steps for and to hold any election, or to make any appointment :
- (d) compelling

PART VII.
DIVISION III.*Vermin Act.—1931.*

(d) compelling any person or persons to proceed to any ballot that may be necessary :

(e) quashing any rate which for any reason is invalid :

(f) compelling the production or delivery of any books, voting-papers, or documents by or to the Board, or any officer thereof, to or by any person.

(3) No order to admit or restore any person to any office or place shall be made whilst any other person is in possession of the office or place.

Provisions on non-compliance with order.
Ibid., s. 265.

266. On non-compliance with any order made by a Court of Summary Jurisdiction, under the provisions of section 265, the following provisions shall apply :—

I. A Court of Summary Jurisdiction may, on complaint laid at the instance of the Board, or by any ratepayer or person interested, order any sum of money to be paid by or to the Board, or any officer thereof, to or by any person, as compensation for any injury sustained by reason of the non-compliance with the order :

II. The said Court may order any such officer or person to be imprisoned, either for a specified time not exceeding six months, or until the aforesaid order is obeyed, and such imprisonment may be ordered in addition to or without any order for payment of money as aforesaid :

III. On non-compliance with any order commanding anything to be done by the Board, a Court of Summary Jurisdiction may order the payment of any sum of money by, or the imprisonment of, any person who would before the passing of the Vermin Act, 1905, have been liable to attachment, or subject to process of contempt, for disobedience to any peremptory writ of *mandamus* issued out of the Supreme Court commanding the Board to do the act directed by the order.

Time within which proceedings may be taken.
Ibid., s. 266.

267. No proceedings to try the title of any person to any office or place on, or in the gift of, a Board shall be had or taken except upon a complaint laid within two months from the time when the person whose title is disputed was appointed or elected, or the cause arose by reason whereof such person is liable to be ousted, whichever last happens.

Limitation of time for trying validity of rate.
Ibid., s. 267.

268. No proceedings to try the validity of any rate under Part III. shall be had or taken except upon a complaint laid within two months from the time when notice of the rate has appeared in the *Gazette*.

Limitation of time for actions against members of a Board, &c.
Ibid., s. 268.

269. (1) All prosecutions for the infliction of pecuniary penalties upon, and all actions against, any member or Chairman of a Board or any officer or other person for anything done or omitted to be done

*Vermin Act.—1931.*PART VII.
DIVISION III.

done in pursuance of Part III. shall be commenced within six months after the happening of the cause of prosecution or action, and not otherwise, except as hereinbefore to the contrary provided.

(2) Notice in writing of every such action, and of the cause thereof, shall be given to the defendant one month at least before the commencement of the action.

(3) The defendant in any such action may plead the general issue, and give this Act and the special matter in evidence at the trial.

(4) The plaintiff shall not recover in any such action if tender of sufficient amends is made before action brought, or if, after action brought, the defendant pays into Court sufficient amends; but in such last-mentioned case the plaintiff shall recover his costs of suit up to the time of payment into Court.

(5) If a verdict passes for the defendant, or the plaintiff becomes nonsuit, or discontinues, or the defendant otherwise recovers judgment, he shall recover full costs as between solicitor and client, and shall have his remedy for the same in the usual way.

270. A District Council, Vermin Board, or Associated Board may remit, in whole or in part, a pecuniary penalty imposed by or under this Act, or a penalty which the Council, Board, or Associated Board is authorised to receive by virtue of this Act, except a penalty imposed for an offence under section 23 or section 43.

Power of Board to remit fines except for failure to destroy vermin.
Ibid., s. 269.
1955, 1930, s. 24.

271. The imposition of a penalty for an offence under Part III. shall not affect any action or other remedy at the instance of the Board, or any person for compensation for, or for the prevention of, injury that may result from the offence.

Conviction not to bar other remedy.
1181, 1914, s. 270.

272. All fines and penalties for offences against any provisions of this Act, other than sections 226, 227, 231, 239, 240 and 241, may be recovered summarily on a complaint at the instance (except where otherwise expressly provided) of any person or persons whomsoever.

Summary procedure for offences.
Ibid., s. 271.

273. Any amount which any occupier is liable to pay to any other occupier under the provisions of Part V. may be recovered in any Court of competent jurisdiction.

Recovery of share of cost from other occupier.
Ibid., s. 272.

274. (1) In every case of the imposition of a fine or pecuniary penalty or the award of amends under this Act, and of the non-payment of the fine or pecuniary penalty or amends, any Justice may commit the person making default in payment to any gaol in the State, for any time not exceeding three months, the imprisonment to cease on payment of the sum due and the costs of any proceedings which have been taken for the recovery thereof.

Power to imprison on non-payment of penalties.
Ibid., s. 274.

(2) This section shall not affect any remedy under the Justices Act, 1921, for the recovery of any fine or any pecuniary penalty or amends.

No. 1479 of 1921.

275. All

PART VII.
DIVISION III.

Vermin Act.—1931.

Allocation of fines
and penalties.
Ibid., s. 278.

275. All fines, penalties, and forfeitures recovered before a Court of Summary Jurisdiction for offences against this Act committed within the District of a Vermin Board, District Council, or Associated Board, shall, except where otherwise provided, be paid to that Vermin Board, District Council, or Associated Board (as the case may be), save such portion of any such fine, penalty, or forfeiture as may by law be appropriated to any informer other than the Vermin Board, District Council, or Associated Board or an officer thereof.

In the name and on behalf of His Majesty, I hereby assent to
this Bill.

A. HORE-RUTHVEN, Governor.

Vermin Act.—1931.

SCHEDULES.

THE FIRST SCHEDULE.

ACTS CONSOLIDATED AND REPEALED.

Reference to Act.	Short Title.	Extent of Repeal.
No. 1181 of 1914.....	The Vermin Act, 1914	The whole.
No. 1203 of 1915.....	Vermin Act Suspensory Act, 1915	The whole.
No. 1249 of 1916	Vermin Act Amendment Act, 1916 ..	The whole.
No. 1398 of 1919	Vermin Act Further Amendment Act, 1919	The whole.
No. 1528 of 1922	Vermin Act Further Amendment Act, 1922	The whole.
No. 1567 of 1923	Vermin Act Further Amendment Act, 1923	The whole.
No. 1631 of 1924	Vermin Act Further Amendment Act, 1924	The whole.
No. 1703 of 1925.....	State Bank Act, 1925	Section 66 and the Fifth Schedule.
No. 1749 of 1926	Vermin Act Further Amendment Act, 1926	The whole.
No. 1869 of 1928	Vermin Act Further Amendment Act, 1928	The whole.
No. 1955 of 1930.....	Vermin Act Amendment Act, 1930 ..	The whole.
No. 1990 of 1930.....	Crown Lands (Administration) Act, 1930	Section 4 and the Second Schedule.
No. 2017 of 1931.....	Vermin Act Amendment Act, 1931 ..	The whole.

THE SECOND SCHEDULE.

A RABBIT-PROOF FENCE.

Section 4.
1181, 1914, Second Schedule.

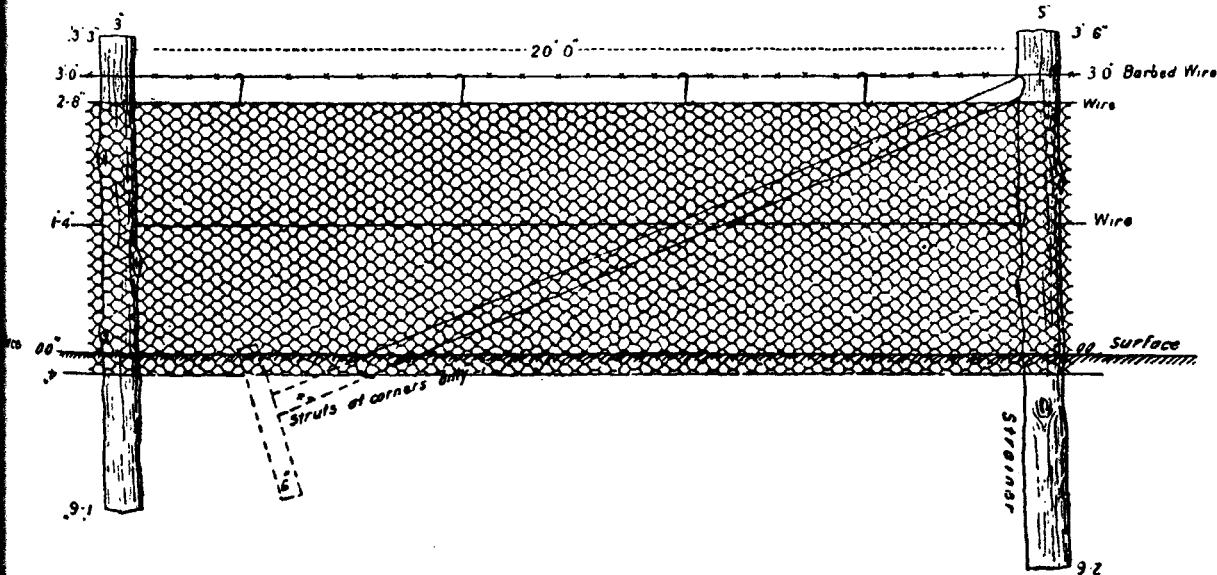

Strainers not less than about five inches in thickness at smaller end, one hundred and fifty yards apart, two feet six inches in the ground, three feet six inches out of ground.

Posts

Vermin Act.—1931.

Posts of approved timber not less than three inches in thickness at smaller end, twenty feet apart, eighteen inches in the ground, three feet three inches out of the ground.

A wire netting of not less than eighteen gauge, of a minimum width of thirty-six inches and maximum mesh of one and a half inches, four inches of such netting to be fixed in the ground and thirty-two inches out of the ground.

Two plain wires—one foot four inches and two feet eight inches above the surface, one barbed wire three feet from the ground, hung with S hooks, four feet apart.

Optional as to the use of a plain wire on or below the surface.

Section 4.
1869, 1928, s. 9.

THE THIRD SCHEDULE.
A DOG-PROOF FENCE.

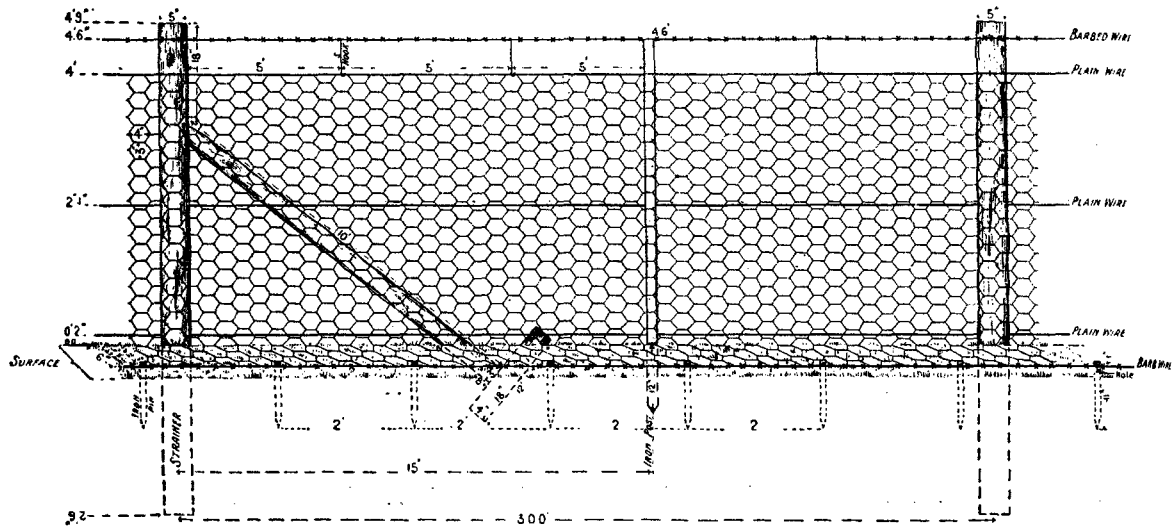

Strainers not less than about five inches in thickness at smaller end, one hundred yards apart, two feet six inches in the ground, fifty-seven inches out of ground.

Iron posts to be used, fifteen feet apart, twelve inches in the ground, fifty-four inches out of the ground.

A wire netting, seventeen gauge, of a minimum width of fifty-four inches and maximum mesh of three inches by four inches, to be erected on the outside of the fence, forty-eight inches to be above the surface of the ground, and a six inch ground lap. The lap to be held in place and secured by means of a twelve inch by one inch by a quarter inch flat iron pin every two feet, with a hole punched one inch from top thereof, driven into the ground for a depth of eleven inches at outer edge of six inch ground lap, with one fourteen gauge by three inch barbed wire well strained, and the barbed wire and wire netting secured to the pin by not less than twelve and a half gauge galvanized-iron wire.

A barbed wire, with barbs not more than three inches apart, fifty-four inches above the surface. The barbed wire to be fastened to the post with a number ten gauge galvanized wire staple put through a hole in the post and turned up on the other side, and connected with number ten gauge galvanized wire S hooks every five feet to the plain wire at four feet and the top of the netting.

Three number ten, or twelve and a half gauge high tensile, galvanized plain wires—two inches, two feet one inch, and four feet above the surface.

All tie wires except where otherwise specified to be of sixteen or eighteen gauge galvanized-iron wire, and well and securely made at equal intervals to each fifteen feet panel, securing the netting to the respective wires as follows:—

Six to plain wire two inches above surface.

Six to plain wire two feet one inch above surface.

Ten to plain wire four feet above surface.

All

Vermin Act.—1931.

All strainers at corners, gateways, angles, and terminations to be provided with struts ten feet long by not less than three inches in diameter, of approved timber, the smaller end to be wedge-shaped and let one inch into the side of the strainer eighteen inches from the top, and the butt end to be embedded eight inches in the ground, and placed against a block of approved timber eighteen inches long by four inches diameter sunk twelve inches in the ground.

THE FOURTH SCHEDULE.
A VERMIN FENCE.

Section 4.
1181, 1914, Third
Schedule.

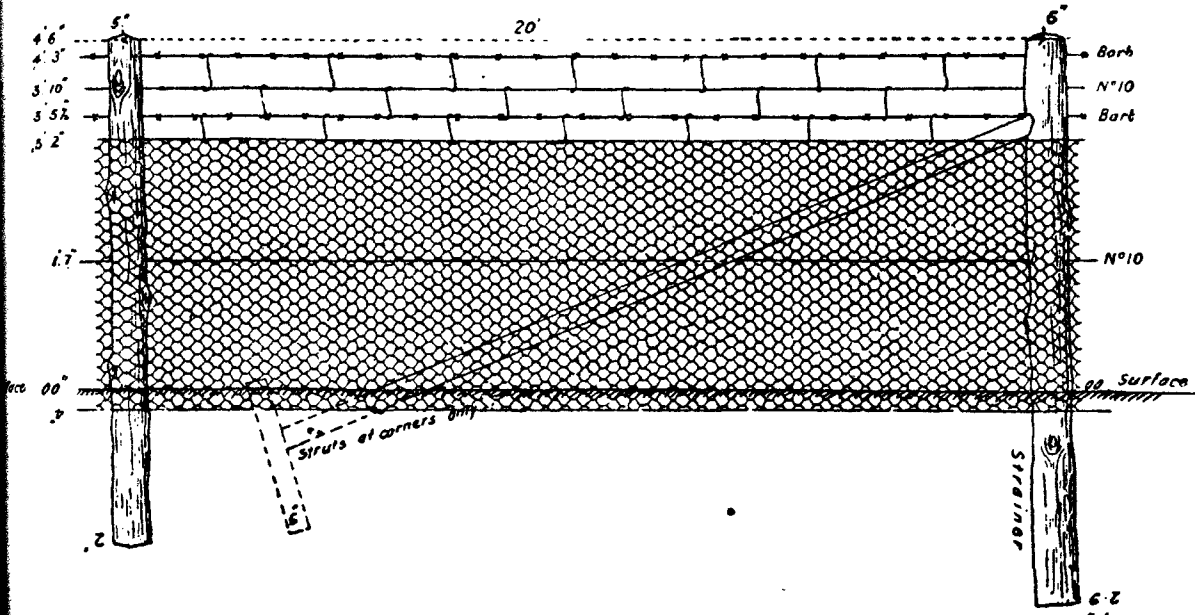

Strainers not less than about six inches in thickness at smaller end, one hundred and fifty yards apart, two feet nine inches in the ground, fifty-four inches out of ground.

Posts not less than about five inches in thickness at smaller end, twenty feet apart, twenty-four inches in the ground, fifty-four inches out of the ground.

A wire netting, eighteen gauge, of a minimum width of forty-two inches and maximum mesh of one and a half inches, four inches of such netting to be fixed in the ground and thirty-eight inches out of the ground.

A barbed wire, with barbs not more than three inches apart, three and a half inches above netting hung with S hooks three feet apart.

A second top similar barbed wire hung with S hooks nine and a half inches above other barbed wire.

The barbed wires to be fastened to the post with a wire staple put through a hole in the post and turned up on the other side.

Two number ten plain wires—one foot seven inches and three feet ten inches above the surface.

Optional as to the use of a barbed or plain wire on or below the surface.

THE FIFTH SCHEDULE.

Vermin Act, 1931.

NOTICE TO DESTROY VERMIN.

Section 22.
1181, 1914, Fourth
Schedule.

To Mr. [name of owner or occupier] of [his address and occupation].

Take notice that I, the undersigned, being an authorised person under the above Act, do hereby pursuant to the provisions of the said Act, require you forthwith to destroy all vermin upon the land occupied by you in [hundred or other locality of land]

*Vermin Act.—1931.*FORM No. 3.
COMPLAINT.South [Royal Arms] Australia.
(To wit.)Section 43.
1181, 1914, Fifth
Schedule.
1567, 1923, s. 13.

The complaint of _____ of _____ an authorised person within the meaning of Part II. of the Vermin Act, 1931, taken this _____ day of _____ 19____, before the undersigned, a Justice of the Peace for the State of South Australia, who [upon oath *or* affirmation] states that _____ of _____ being the owner [or occupier *as the case may be*] of certain land, namely [*here sufficiently describe the land*] and being as such owner [or occupier] bound by section 40 of the said Act to destroy the vermin upon a certain breakwind reserve [or a certain breakwind reserve and a certain road (or roads) adjoining the same] [or a certain part (or parts) of a certain breakwind reserve (or of a certain breakwind reserve and a certain road (or certain roads) adjoining the same)] did not during the simultaneous vermin destruction months of [*here state the simultaneous vermin destruction months for the Pinnaroo Railway District*] in the year 19____, destroy all vermin upon the said reserve [or the said reserve and road (or roads)] [or the said part (or parts) of the said reserve (or the said reserve and road or roads)] contrary to the provisions of the Vermin Act, 1931.

Taken [and sworn *or* affirmed] before me, }
the day and year first above mentioned at }
in the said State. }

*Justice of the Peace.*FORM No. 4.
COMPLAINT.South [Royal Arms] Australia.
(To wit.)Section 43.
1181, 1914, Fifth
Schedule.

The complaint of _____ of _____ an authorised person within the meaning of Part II. of the Vermin Act, 1931, taken this _____ day of _____ 19____, before the undersigned, a Justice of the Peace for the State of South Australia, who [upon oath *or* affirmation] states that _____ of _____ being the owner [or occupier *as the case may be*] of certain land, namely [*here sufficiently describe the land*] and being as such owner [or occupier] bound by section 40 of the said Act to destroy the vermin upon a certain breakwind reserve [or a certain breakwind reserve and a certain road (or certain roads) adjoining the same] [or a certain part (or parts) of a certain breakwind reserve (or of a certain breakwind reserve and a certain road (or certain roads) adjoining the same)] did not, within the time prescribed by the Commissioner of Crown Lands under section 23 of the Vermin Act, 1931, after the service upon him of a notice under section 22 of the said Act destroy all vermin upon the said reserve [or the said reserve and road (or roads)] [or the said part (or parts) of the said reserve (or the said reserve and road or roads)] contrary to the provisions of the Vermin Act, 1931.

Taken [and sworn *or* affirmed] before me, }
the day and year first above mentioned }
at _____ in the said State. }

*Justice of the Peace.*THE SEVENTH SCHEDULE.
Vermin Act, 1931.Section 31.
1181, 1914, Sixth
Schedule.

NOTICE OF MONEYS PAYABLE FOR DESTRUCTION OF VERMIN.

Notice is hereby given that there is now due and payable in respect of the cost and expense of the destruction of vermin upon the land (or lands, *as the case may be*) mentioned in the Schedule hereto, the sum set opposite to the description of the

Vermin Act.—1931.

said land (or lands), and the owner or owners of the said land (or lands) are required to take notice that unless the amount (or amounts) so due, together with the cost of and attending this notice, are paid to the [set out name of District Council, Associated Board, or Vermin Board, or Commissioner of Crown Lands, as the case may require] on or before the day of , 19 [one month from the third publication of this notice], the said [District Council, Board, or Commissioner, as the case may be] will let such of the said land (or lands) in respect of which any money shall be then unpaid, from year to year, in manner provided by the Vermin Act, 1931, or apply to the Supreme Court for an order for the sale of the said land (or lands) or so much thereof as may be necessary to produce the amount or amounts remaining unpaid, and also the costs of and attending the application and sale.

Dated this day of 19 .

*

The Schedule referred to.

Description of land.	Name of Owner or Occupier (if unknown, state so.)	Amount due.		
		£	s.	d.

* Signature of Chairman of District Council, Associated Board, or Vermin Board, or Commissioner (as the case may be).

Section 76.
1181, 1914, Seventh
Schedule.

THE EIGHTH SCHEDULE

FORM No 1.

Vermin-Fenced District of .—Annual Election, 19 .

Nominations will be received at the Vermin Board Office for the District of at , up to 12 o'clock noon on , the day of , 19 , for members of the Board, and for auditors. Should more than the required number be nominated, either for members of the Board or for auditors, further proceedings will be adjourned until , the day of , 19 , when an election will take place by ballot.

Dated the day of , 19 .

By order,

Secretary.

FORM No. 2.

NOMINATION OF MEMBER OF VERMIN BOARD.

Vermin-Fenced District of .—Annual Election, 19 .

We, the undersigned, ratepayers of the Vermin-Fenced District of , do hereby nominate [here state names of candidates in full, with address and occupation] as a candidate for the office of a member of the Vermin Board of such District at the election to be held on the day of 19 .

{ Signatures of
Nominators.

I, the above-named

, hereby consent to the above nomination.

[Signature of Candidate.]

Vermin Act.—1931.

FORM No. 3.
FORM OF PROXY.

I, _____, of _____, being a ratepayer of the Vermin-Fenced District of _____, in respect of [*here state land*] and entitled to votes for the election of members of the Board (and auditors) for the said District, hereby appoint _____, of _____, as my proxy to vote for me and on my behalf at the election of members of the said Board (and auditors) to be held on the _____ day of _____, 19____.

As witness my hand this _____ day of _____, 19____.

Signed by the said _____ }
in the presence of _____ }

FORM No. 4.
VOTING-PAPER.

I, the undersigned being entitled to _____ votes for the election of members of the Vermin Board (*or auditors*) of the District of _____, hereby vote for _____, of _____ and _____ of _____, as members of the Board (*or auditors*) for the said District.

Dated this _____ day of _____, 19____.

*Signature.	Address.	Number of Votes.

* If the vote is given by proxy the signature should be "A.B. (*person entitled to vote*) by his duly authorised proxy."

THE NINTH SCHEDULE.

I, _____, of _____, do hereby solemnly and sincerely declare that all the signatures [*or, if the case so require, such and such signatures (describing them as initialled or otherwise marked by the declarant)*] affixed to the above petition are the genuine signatures of the persons whose signatures they purport to be, and that such persons are occupiers of land in the area therein referred to.

Section 163.
1181, 1914, Eighth
Schedule.

Declared at _____ }
this _____ day of _____, }
19____, before me, _____ }
Justice of the Peace.

THE TENTH SCHEDULE.

Vermin Act, 1931.
UNDERTAKING TO REPAY LOAN.

Section 166.
1181, 1914, Ninth
Schedule.
1703, 1925, s. 66

The District Council of _____ hereby makes application to the State Bank of South Australia, pursuant to section 166 of the Vermin Act, 1931, for a loan of £ _____, in accordance with a petition which accompanies this application; and the said District Council hereby undertakes to repay the amount of the loan in accordance with the provisions of the said Act.

Dated this _____ day of _____, 19____.

_____, Chairman.
_____, Councillor.
_____, Clerk.



THE

Vermin Act.—1931.

Section 189.
1181, 1914, Tenth
Schedule.

THE ELEVENTH SCHEDULE.

Vermin Act, 1931.

NOTICE OF MONEYS PAYABLE FOR WIRE NETTING.

Notice is hereby given that there is now due and payable in respect of wire netting furnished in respect of (*or* furnished and erected on) the land (*or* lands, *as the case may be*) mentioned in the Schedule hereto the sum [*or* sums set opposite to the description of the said land (*or* lands)]; and the occupier (*or* occupiers) of the said land (*or* lands) is (*or* are) required to take notice that unless the amount (*or* amounts) so due, together with the cost of and attending this notice, is (*or* are) paid to the [*set out name of Vermin Board*] on or before the

day of 19 [*one month from the third publication of the notice*], the said Board will let such of the said land (*or* lands) in respect of which any money is then unpaid, from year to year, in manner provided by the Vermin Act, 1931, or will apply to the Supreme Court for an order for the sale of said land (*or* lands), or so much thereof as may be necessary to produce the amount (*or* amounts) remaining unpaid, and also the costs of and attending the application and sale.

Dated this _____ day of _____ 19 .

[*Signature.*]

Chairman of [*name of Board*].

The Schedule referred to.

Description of Land.	Name of Occupier (<i>if unknown state so</i>).	Amount due.		
		£	s.	d.

Vermin Act.—1931.

VERMIN ACT, 1931.

TABLE SHOWING HOW THE SECTIONS OF THE ACTS CONSOLIDATED HAVE BEEN DEALT WITH.

Section of Repealed Act.	Remarks.	Section of Consolidating Act.
The Vermin Act, 1914..... s. 1	Short title.....	—
Ibid. s. 2	Arrangement of Act	—
“ s. 3	Repealing provision	—
“ s. 4	As amended by 1249, 1916, s. 4; 1703, 1925, s. 66; 1869, 1928, s. 3, and 1990, 1930, s. 4. The defini- tions of “Any land”, “By-law”, “Court”, “Fences Acts”, “Gazette”, “Judge”, “Justice”, “Proclamation”, “Regulation”, “State”, “Sur- veyor-General”, and “This Act” have been deleted as unnecessary	4
“ s. 5	5
“ s. 6	As amended by 1249, 1916, s. 4, and 1990, 1930, s. 4.	6
“ s. 7	7
“ s. 8	The words “Subject to section 41” have been inserted to give effect to 1631, 1924, s. 6 (2)	8
“ s. 9	Subsection (3) deleted as unnecessary	9
“ s. 10	10
“ s. 11	11
“ s. 12	12
“ s. 13	As amended by 1955, 1930, s. 6	13
“ s. 14	14
“ s. 15	15
“ s. 16	16
“ s. 17	As enacted by 1398, 1919, s. 3, and amended by 1567, 1923, s. 3	17
“ s. 18	Subsection (1) re-drafted to give effect to section 222 of the District Councils Act, 1929	18
“ s. 19	19
“ s. 20	As amended by 1398, 1919, s. 4, and 1567, 1923, s. 4....	20
“ s. 21	21
“ s. 22	22
“ s. 23	As amended by 1567, 1923, s. 5	23
“ s. 24	As amended by 1567, 1923, s. 6	24
“ s. 25	25
“ s. 26	As amended by 1567, 1923, s. 7	26
“ s. 27	As amended by 1567, 1923, s. 8	27
“ s. 28	28
“ s. 29	29
“ s. 30	As amended by 1955, 1930, s. 7	30
“ s. 31	31
“ s. 32	32
“ s. 33	33
“ s. 34	34
“ s. 35	35
“ s. 36	As amended by 1955, 1930, s. 8. The words “by him” in paragraph (b) deleted in order to give effect to the obvious meaning thereof.	36
“ s. 37	37
“ s. 37A	As enacted by 1528, 1922, s. 3	38
“ s. 38	As amended by 1567, 1923, s. 9	39
“ s. 39	As amended by 1955, 1930, s. 9	40
“ s. 40	42

Vermin Act.—1931.

Table Showing how the Sections of the Acts Consolidated have been dealt with—continued.

Section of Repealed Act.	Remarks.	Section of Consolidating Act.
The Vermin Act, 1914. s. 41	As amended by 1567, 1923, s. 10, and 1955, 1930, s. 10	43
Ibid. s. 42	As amended by 1249, 1916, s. 4; 1955, 1950, s. 11, and 1990, 1930, s. 4	44
“ s. 43	45
“ s. 44	As amended by 1869, 1928, s. 4	46
“ s. 45	47
“ s. 46	As amended by 1869, 1928, s. 4, and 1955, 1930, s. 12.	48
“ s. 47	As amended by 1955, 1930, s. 13	49
“ s. 48	50
“ s. 49	51
“ s. 50	52
“ s. 51	53
“ s. 52	54
“ s. 53	55
“ s. 54	As amended by 1955, 1930, s. 14	56
“ s. 55	The word “without” in the last line of subsection (2) has been deleted	57
“ s. 56	58
“ s. 57	59
“ s. 58	60
“ s. 59	61
“ s. 60	62
“ s. 61	63
“ s. 62	64
“ s. 63	65
“ s. 64	66
“ s. 65	67
“ s. 66	Deleted as unnecessary	—
“ s. 67	68
“ s. 68	69
“ s. 69	70
“ s. 70	71
“ s. 71	As amended by 2017, 1931, s. 2	72
“ s. 72	73
“ s. 73	80
“ s. 74	As amended by 1249, 1916, s. 4, and 1990, 1930, s. 4.	74
“ s. 75	75
“ s. 76	76
“ s. 77	77
“ s. 78	78
“ s. 79	79
“ s. 80	81
“ s. 81	As amended by 1955, 1930, s. 15	82
“ s. 82	83
“ s. 83	84
“ s. 84	85
“ s. 85	86
“ s. 86	87
“ s. 87	88
“ s. 88	89
“ s. 89	90
“ s. 90	91
“ s. 91	92
“ s. 92	93
“ s. 93	94
“ s. 94	95

*Vermin Act.—1931.**Table Showing how the Sections of the Acts Consolidated have been dealt with—continued.*

Section of Repealed Act.	Remarks.	Section of Consolidating Act.
The Vermin Act, 1914..... s. 95	96
Ibid. s. 96	97
" s. 97	98
" s. 98	99
" s. 99	100
" s. 100	101
" s. 101	102
" s. 102	As amended by 1869, 1928, s. 4	103
" s. 103	As amended by 1869, 1928, s. 4	104
" s. 104	105
" s. 105	106
" s. 106	107
" s. 107	108
" s. 108	As amended by 1955, 1930, s. 16	109
" s. 109	As amended by 1869, 1928, s. 4	110
" s. 110	As amended by 1869, 1928, s. 4	111
" s. 111	As amended by 1869, 1928, s. 4	112
" s. 112	As amended by 1955, 1930, s. 17	113
" s. 113	As amended by 1869, 1928, s. 4	114
" s. 114	As amended by 1398, 1919, s. 5 ; 1703, 1925, s. 66 ; and 1869, 1928, s. 4	115
" s. 115	As amended by 1869, 1928, s. 4, and re-enacted by 1955, 1930, s. 18	116
" s. 116	117
" s. 117	118
" s. 118	Paragraph (c) re-drafted to give effect to its obvious meaning. As amended by 1955, 1930, s. 19	119
" s. 119	120
" s. 120	121
" s. 121	122
" s. 122	123
" s. 123	124
" s. 124	As amended by 1528, 1922, s. 4 ; 1749, 1926, s. 2 ; and 1869, 1928, s. 4	125
" s. 125	126
" s. 126	127
" s. 126A	As enacted by 1398, 1919, s. 6.	128
" s. 127	129
" s. 128	As amended by 1703, 1925, s. 66, and 1749, 1926, s. 3	130
" s. 128A	As enacted by 1398, 1919, s. 7, and amended by 1703, 1925, s. 66, and 1749, 1926, s. 4	131
" s. 129	132
" s. 130	133
" s. 131	As enacted by 1703, 1925, s. 66	134
" s. 132	135
" s. 133	As amended by 1703, 1925, s. 66	136
" s. 134	Paragraphs (b) and (c) deleted as unnecessary in view of the provisions of the Acts Interpretation Act, 1915	137
" s. 135	138
" s. 136	139
" s. 137	140
" s. 138	141
" s. 139	142
" s. 140	143

Vermin Act.—1931.

Table Showing how the Sections of the Acts Consolidated have been dealt with—continued.

Section of Repealed Act.	Remarks.	Section of Consolidating Act.
The Vermin Act,		
1914..... s. 141	144
Ibid. s. 142	145
"..... s. 143	146
"..... s. 144	147
"..... s. 145	148
"..... s. 146	149
"..... s. 147	150
"..... s. 148	151
"..... s. 149	152
"..... s. 150	As amended by 2017, 1931, s. 3	153
"..... s. 151	—
"..... s. 152	—
"..... s. 153	} Repealed by 1955, 1950, s. 20 (1).....	—
"..... s. 154	}	—
"..... s. 155	}	—
"..... s. 156	As amended by 1249, 1916, s. 4; 1869, 1928, s. 4, and 1990, 1930, s. 4	154
"..... s. 157	155
"..... s. 158	156
"..... s. 159	As amended by 1869, 1928, s. 4	157
"..... s. 160	As amended by 1703, 1925, s. 66	158
"..... s. 161	159
"..... s. 162	Operation exhausted	—
"..... s. 163	As amended by 1703, 1925, s. 66	160
"..... s. 164	161
"..... s. 165	As amended by 1631, 1924, s. 2, and 1703, 1925, s. 66 ..	162
"..... s. 166	163
"..... s. 167	164
"..... s. 168	165
"..... s. 169	As amended by 1703, 1925, s. 66	166
"..... s. 170	As amended by 1703, 1925, s. 66	167
"..... s. 171	168
"..... s. 172	As amended by 1703, 1925, s. 66	169
"..... s. 173	170
"..... s. 174	As amended by 1703, 1925, s. 66	171
"..... s. 175	172
"..... s. 176	As amended by 1703, 1925, s. 66	173
"..... s. 177	174
"..... s. 178	Subsection (3) re-drafted	175
"..... s. 179	176
"..... s. 180	As amended by 1703, 1925, s. 66	177
"..... s. 181	As amended by 1703, 1925, s. 66	178
"..... s. 182	179
"..... s. 183	180
"..... s. 184	181
"..... s. 185	182
"..... s. 186	183
"..... s. 187	184
"..... s. 188	As amended by 1703, 1925, s. 66	185
"..... s. 189	As enacted by 1398, 1919, s. 8, and amended by 1703, 1925, s. 66	186
"..... s. 190	As amended by 1703, 1925, s. 66, and 1869, 1928, s. 4.	187
"..... s. 191	188
"..... s. 192	189
"..... s. 193	190

*Vermin Act.—1931.**Table Showing how the Sections of the Acts Consolidated have been dealt with—continued.*

Section of Repealed Act.	Remarks.	Section of Consolidating Act.
The Vermin Act, 1914..... s. 194	191
Ibid. s. 195	192
" s. 196	193
" s. 197	194
" s. 198	195
" s. 199	As amended by 1703, 1925, s. 66	196
" s. 200	197
" s. 201	Repealed by 1631, 1924, s. 3	—
" s. 202	As amended by 1631, 1924, s. 4 ; 1703, 1925, s. 66 ; and 1869, 1928, s. 4	198
" s. 203	As amended by 1869, 1928, s. 4	199
" s. 204	As amended by 1703, 1925, s. 66	200
" s. 205	As amended by 1631, 1924, s. 5, and 1869, 1928, s. 4	201
" s. 206	As amended by 1869, 1928, s. 4	202
" s. 207	As amended by 1869, 1928, s. 5	203
" s. 208	As amended by 1869, 1928, s. 4	204
" s. 209	As amended by 1869, 1928, ss. 4 and 6	205
" s. 210	As amended by 1869, 1928, s. 4	206
" s. 211	As amended by 1869, 1928, s. 4	207
" s. 212	As amended by 1869, 1928, s. 4	208
" s. 213	As amended by 1869, 1928, ss. 4 and 7	209
" s. 214	As amended by 1869, 1928, s. 4	210
" s. 215	As amended by 1869, 1928, s. 4	211
" s. 216	212
" s. 217	213
" s. 218	214
" s. 219	215
" s. 220	As amended by 1703, 1925, s. 66	216
" s. 221	"Council" substituted for "Corporation" in subsection (1).	217
" s. 222	218
" s. 223	As amended by 1249, 1916, s. 4 ; 1567, 1923, s. 11, and 1990, 1930, s. 4	219
" s. 224	220
" s. 225	221
" s. 226	As amended by 1955, 1930, s. 21	226
" s. 227	227
" s. 228	228
" s. 229	As amended by 1869, 1928, s. 4	229
" s. 230	As amended by 1869, 1928, s. 8	230
" s. 231	231
" s. 232	232
" s. 233	233
" s. 234	234
" s. 235	235
" s. 236	236
" s. 237	237
" s. 238	238
" s. 239	239
" s. 240	240
" s. 241	241
" s. 242	242
" s. 243	243
" s. 244	244
" s. 245	As amended by 1955, 1930, s. 22	245
" s. 246	246

Vermin Act.—1931.

Table Showing how the Sections of the Acts Consolidated have been dealt with—continued.

Section of Repealed Act.	Remarks.	Section of Consolidating Act.
The Vermin Act,		
1914..... s. 247	247
Ibid. s. 248	248
" s. 249	249
" s. 250	250
" s. 251	251
" s. 252	252
" s. 253	253
" s. 254	254
" s. 255	255
" s. 256	As amended by 1955, 1930, s. 23.....	256
" s. 256A	As enacted by 1567, 1923, s. 12. and amended by 1955, 1930, s. 26	257
" s. 257	258
" s. 258	259
" s. 259	260
" s. 260	261
" s. 261	262
" s. 262	263
" s. 263	264
" s. 264	265
" s. 265	266
" s. 266	267
" s. 267	268
" s. 268	269
" s. 269	As amended by 1955, 1930, s. 24	270
" s. 270	271
" s. 271	272
" s. 272	273
" s. 273	Deleted as unnecessary in view of the provisions of the Justices Act, 1921	—
" s. 274	274
" s. 275	} Deleted as unnecessary in view of the provisions of the Justices Act, 1921	—
" s. 276		—
" s. 277		—
" s. 278	275
" First Schedule	Acts consolidated and repealed	—
" Second Schedule	Second Schedule
" Third Schedule	Fourth Schedule
" Fourth Schedule	Fifth Schedule
" Fifth Schedule	As amended by 1567, 1923, s. 13. The forms have been re-drafted to conform with the provisions of the Justices Act, 1921.	Sixth Schedule
" Sixth Schedule	Seventh Schedule
" Seventh Schedule	Eighth Schedule
" Eighth Schedule	Ninth Schedule
" Ninth Schedule	As amended by 1703, 1925, s. 66	Tenth Schedule
" Tenth Schedule	Eleventh Schedule
" Eleventh Schedule	As enacted by 1869, 1928, s. 9.....	Third Schedule
Vermin Act Suspensory Act, 1915 ... s. 1	Short title.....	—
Ibid. s. 2	Incorporation.....	—
" s. 3	} Operation exhausted	—
" s. 4		—
" s. 5		—

*Vermin Act.—1931.**Table Showing how the Sections of the Acts Consolidated have been dealt with—continued.*

Section of Repealed Act.	Remarks.	Section of Consolidating Act.
Vermin Act Amend- ment Act, 1916 . . . s. 1	Short titles	—
Ibid. s. 2	Incorporation	—
“ s. 3	Commencement	—
“ s. 4	Effect contained in Schedule	—
“ Schedule		4, 6, 44, 74, 151, and 219
Vermin Act Further Amendment Act, 1919. s. 1	Short titles	—
Ibid. s. 2	Incorporation	—
“ s. 3	Re-enactment of 1181, 1914, s. 17, and as amended by 1567, 1923, s. 3	17
“ s. 4	Amendment of 1181, 1914, s. 20, and as amended by 1567, 1923, s. 4	20
“ s. 5	Amendment of 1181, 1914, s. 114, and as amended by 1703, 1925, s. 66, and 1869, 1928, s. 4.	115
“ s. 6		128
“ s. 7	As amended by 1703, 1925, s. 66, and 1749, 1926, s. 4	131
“ s. 8	Re-enactment of 1181, 1914, s. 189, and as amended by 1703, 1925, s. 66	186
“ s. 9	As amended by 1631, 1924, s. 6 (1), and amended so as to give effect to 2000, 1931, s. 3	41
“ s. 10		42
“ s. 11	As amended by 1567, 1923, s. 14, and 1955, 1930, s. 25	43
Vermin Act Further Amendment Act, 1922. s. 1	Short titles	—
Ibid. s. 2	Incorporation	—
“ s. 3		38
“ s. 4	Amendment of 1181, 1914, s. 124	125
Vermin Act Further Amendment Act, 1923. s. 1	Short titles	—
Ibid. s. 2	Incorporation	—
“ s. 3	Amendment of 1181, 1914, s. 17, as enacted by 1398, 1919, s. 3	17
“ s. 4	Amendment of 1181, 1914, s. 20	20
“ s. 5	Amendment of <i>ibid.</i> , s. 23	23
“ s. 6	Amendment of <i>ibid.</i> , s. 24	24
“ s. 7	Amendment of <i>ibid.</i> , s. 26	26
“ s. 8	Amendment of <i>ibid.</i> , s. 27	27
“ s. 9	Amendment of <i>ibid.</i> , s. 38	39
“ s. 10	Amendment of <i>ibid.</i> , s. 41	43
“ s. 11	Amendment of <i>ibid.</i> , s. 223	219
“ s. 12	As amended by 1955, 1930, s. 26	257
“ s. 13	Amendment of 1118, 1914, Fifth Schedule.	Sixth Schedule
“ s. 14	Amendment of 1398, 1919, s. 11	43
Vermin Act Further Amendment Act, 1924. s. 1	Short titles	—
Ibid. s. 2	Amendment of 1181, 1914, s. 165	162
“ s. 3	Repeal of <i>ibid.</i> , s. 201	—
“ s. 4	Amendment of <i>ibid.</i> , s. 202	198
“ s. 5	Amendment of <i>ibid.</i> , s. 205	201
“ s. 6	Amendment of 1398, 1919, s. 9	41 and 8

*Vermin Act.—1931.**Table Showing how the Sections of the Acts Consolidated have been dealt with—continued.*

Section of Repealed Act.	Remarks.	Section of Consolidating Act.
State Bank Act, 1925 s. 66	Repealing provision	—
Ibid. Fifth Schedule	Given effect to in sections 4, 115, and 216, in Division X. of Part III., and in Divisions I. to IV. (inclusive) of Part V.	—
Vermin Act Further Amendment Act, 1926. s. 1	Short titles	—
Ibid. s. 2	Amendment of 1181, 1914, s. 124	125
“ s. 3	Amendment of <i>ibid.</i> , s. 128	130
“ s. 4	Amendment of 1398, 1919, s. 7	131
Vermin Act Further Amendment Act, 1928. s. 1	Short titles	—
Ibid. s. 2	Incorporation	—
“ s. 3	Amendment of 1181, 1914, s. 4	4
“ s. 4	Amendment of <i>ibid.</i> as set out in the Schedule	—
“ s. 5	Amendment of <i>ibid.</i> , s. 207	203
“ s. 6	Amendment of <i>ibid.</i> , s. 209	205
“ s. 7	Amendment of <i>ibid.</i> , s. 213	209
“ s. 8	Amendment of <i>ibid.</i> , s. 230	230
“ s. 9	Third Schedule
“ Schedule	Various amendments of 1181, 1914, given effect to throughout the Act	—
Vermin Act Amendment Act, 1930 ... s. 1	Short titles	—
Ibid. s. 2	Incorporation	—
“ s. 3	222
“ s. 4	223
“ s. 5	224
“ s. 6	Amendment of 1181, 1914, s. 13	13
“ s. 7	Amendment of <i>ibid.</i> , s. 30	30
“ s. 8	Amendment of <i>ibid.</i> , s. 36	36
“ s. 9	Amendment of <i>ibid.</i> , s. 39	40
“ s. 10	Amendment of <i>ibid.</i> , s. 41	43
“ s. 11	Amendment of <i>ibid.</i> , s. 42	44
“ s. 12	Amendment of <i>ibid.</i> , s. 46	48
“ s. 13	Amendment of <i>ibid.</i> , s. 47	49
“ s. 14	Amendment of <i>ibid.</i> , s. 54	56
“ s. 15	Amendment of <i>ibid.</i> , s. 81	82
“ s. 16	Amendment of <i>ibid.</i> , s. 108	109
“ s. 17	Amendment of <i>ibid.</i> , s. 112	113
“ s. 18	Amendment of <i>ibid.</i> , s. 115	116
“ s. 19	Amendment of <i>ibid.</i> , s. 118	119
“ s. 20 (1)	Repeal of <i>ibid.</i> , Part IV.	—
“ s. 20 (2)	225
“ s. 21	Amendment of <i>ibid.</i> , s. 226	226
“ s. 22	Amendment of <i>ibid.</i> , s. 245	245
“ s. 23	Amendment of <i>ibid.</i> , s. 256	256
“ s. 24	Amendment of <i>ibid.</i> , s. 269	270
“ s. 25	Amendment of 1398, 1919, s. 11	43
“ s. 26	Amendment of 1567, 1923, s. 12	257
Crown Lands (Administration) Act, 1930 s. 4	—
Ibid. Second Schedule	Given effect to in sections 4, 6, 44, 74, 154, and 219 ..	—
Vermin Act Amendment Act, 1931 .. s. 1	Short titles	—
Ibid. s. 2	Amendment of 1181, 1914, s. 71	72
“ s. 3	Amendment of <i>ibid.</i> , s. 150	153